

# **Complex Analysis**

**George Cain**

# Table of Contents

## **Chapter One - Complex Numbers**

- 1.1 Introduction
- 1.2 Geometry
- 1.3 Polar coordinates

## **Chapter Two - Complex Functions**

- 2.1 Functions of a real variable
- 2.2 Functions of a complex variable
- 2.3 Derivatives

## **Chapter Three - Elementary Functions**

- 3.1 Introduction
- 3.2 The exponential function
- 3.3 Trigonometric functions
- 3.4 Logarithms and complex exponents

## **Chapter Four - Integration**

- 4.1 Introduction
- 4.2 Evaluating integrals
- 4.3 Antiderivatives

## **Chapter Five - Cauchy's Theorem**

- 5.1 Homotopy
- 5.2 Cauchy's Theorem

## **Chapter Six - More Integration**

- 6.1 Cauchy's Integral Formula
- 6.2 Functions defined by integrals
- 6.3 Liouville's Theorem
- 6.4 Maximum moduli

## **Chapter Seven - Harmonic Functions**

- 7.1 The Laplace equation
- 7.2 Harmonic functions
- 7.3 Poisson's integral formula

## **Chapter Eight - Series**

- 8.1 Sequences
- 8.2 Series
- 8.3 Power series
- 8.4 Integration of power series
- 8.5 Differentiation of power series

## **Chapter Nine - Taylor and Laurent Series**

9.1 Taylor series

9.2 Laurent series

## **Chapter Ten - Poles, Residues, and All That**

10.1 Residues

10.2 Poles and other singularities

## **Chapter Eleven - Argument Principle**

11.1 Argument principle

11.2 Rouché's Theorem

---

George Cain  
School of Mathematics  
Georgia Institute of Technology  
Atlanta, Georgia 0332-0160

[cain@math.gatech.edu](mailto:cain@math.gatech.edu)

## Chapter One

# Complex Numbers

**1.1 Introduction.** Let us hark back to the first grade when the only numbers you knew were the ordinary everyday integers. You had no trouble solving problems in which you were, for instance, asked to find a number  $x$  such that  $3x = 6$ . You were quick to answer "2". Then, in the second grade, Miss Holt asked you to find a number  $x$  such that  $3x = 8$ . You were stumped—there was no such "number"! You perhaps explained to Miss Holt that  $3(2) = 6$  and  $3(3) = 9$ , and since 8 is between 6 and 9, you would somehow need a number between 2 and 3, but there isn't any such number. Thus were you introduced to "fractions."

These fractions, or rational numbers, were defined by Miss Holt to be ordered pairs of integers—thus, for instance,  $(8, 3)$  is a rational number. Two rational numbers  $(n, m)$  and  $(p, q)$  were defined to be equal whenever  $nq = pm$ . (More precisely, in other words, a rational number is an equivalence class of ordered pairs, *etc.*) Recall that the arithmetic of these pairs was then introduced: the sum of  $(n, m)$  and  $(p, q)$  was defined by

$$(n, m) + (p, q) = (nq + pm, mq),$$

and the product by

$$(n, m)(p, q) = (np, mq).$$

Subtraction and division were defined, as usual, simply as the inverses of the two operations.

In the second grade, you probably felt at first like you had thrown away the familiar integers and were starting over. But no. You noticed that  $(n, 1) + (p, 1) = (n + p, 1)$  and also  $(n, 1)(p, 1) = (np, 1)$ . Thus the set of all rational numbers whose second coordinate is one behave just like the integers. If we simply abbreviate the rational number  $(n, 1)$  by  $n$ , there is absolutely no danger of confusion:  $2 + 3 = 5$  stands for  $(2, 1) + (3, 1) = (5, 1)$ . The equation  $3x = 8$  that started this all may then be interpreted as shorthand for the equation  $(3, 1)(u, v) = (8, 1)$ , and one easily verifies that  $x = (u, v) = (8, 3)$  is a solution. Now, if someone runs at you in the night and hands you a note with 5 written on it, you do not know whether this is simply the integer 5 or whether it is shorthand for the rational number  $(5, 1)$ . What we see is that it really doesn't matter. What we have "really" done is expanded the collection of integers to the collection of rational numbers. In other words, we can think of the set of all rational numbers as including the integers—they are simply the rationals with second coordinate 1.

One last observation about rational numbers. It is, as everyone must know, traditional to

write the ordered pair  $(n, m)$  as  $\frac{n}{m}$ . Thus  $n$  stands simply for the rational number  $\frac{n}{1}$ , *etc.*

Now why have we spent this time on something everyone learned in the second grade? Because this is almost a paradigm for what we do in constructing or defining the so-called complex numbers. Watch.

Euclid showed us there is no rational solution to the equation  $x^2 = 2$ . We were thus led to defining even more new numbers, the so-called real numbers, which, of course, include the rationals. This is hard, and you likely did not see it done in elementary school, but we shall assume you know all about it and move along to the equation  $x^2 = -1$ . Now we define **complex numbers**. These are simply ordered pairs  $(x, y)$  of real numbers, just as the rationals are ordered pairs of integers. Two complex numbers are equal only when there are actually the same—that is  $(x, y) = (u, v)$  precisely when  $x = u$  and  $y = v$ . We define the sum and product of two complex numbers:

$$(x, y) + (u, v) = (x + u, y + v)$$

and

$$(x, y)(u, v) = (xu - yv, xv + yu)$$

As always, subtraction and division are the inverses of these operations.

Now let's consider the arithmetic of the complex numbers with second coordinate 0:

$$(x, 0) + (u, 0) = (x + u, 0),$$

and

$$(x, 0)(u, 0) = (xu, 0).$$

Note that what happens is completely analogous to what happens with rationals with second coordinate 1. We simply use  $x$  as an abbreviation for  $(x, 0)$  and there is no danger of confusion:  $x + u$  is short-hand for  $(x, 0) + (u, 0) = (x + u, 0)$  and  $xu$  is short-hand for  $(x, 0)(u, 0)$ . We see that our new complex numbers include a copy of the real numbers, just as the rational numbers include a copy of the integers.

Next, notice that  $x(u, v) = (u, v)x = (x, 0)(u, v) = (xu, xv)$ . Now then, any complex number  $z = (x, y)$  may be written

$$\begin{aligned} z &= (x,y) = (x,0) + (0,y) \\ &= x + y(0,1) \end{aligned}$$

When we let  $\alpha = (0,1)$ , then we have

$$z = (x,y) = x + \alpha y$$

Now, suppose  $z = (x,y) = x + \alpha y$  and  $w = (u,v) = u + \alpha v$ . Then we have

$$\begin{aligned} zw &= (x + \alpha y)(u + \alpha v) \\ &= xu + \alpha(xv + yu) + \alpha^2 yv \end{aligned}$$

We need only see what  $\alpha^2$  is:  $\alpha^2 = (0,1)(0,1) = (-1,0)$ , and we have agreed that we can safely abbreviate  $(-1,0)$  as  $-1$ . Thus,  $\alpha^2 = -1$ , and so

$$zw = (xu - yv) + \alpha(xv + yu)$$

and we have reduced the fairly complicated definition of complex arithmetic simply to ordinary real arithmetic together with the fact that  $\alpha^2 = -1$ .

Let's take a look at division—the inverse of multiplication. Thus  $\frac{z}{w}$  stands for that complex number you must multiply  $w$  by in order to get  $z$ . An example:

$$\begin{aligned} \frac{z}{w} &= \frac{x + \alpha y}{u + \alpha v} = \frac{x + \alpha y}{u + \alpha v} \cdot \frac{u - \alpha v}{u - \alpha v} \\ &= \frac{(xu + yv) + \alpha(yu - xv)}{u^2 + v^2} \\ &= \frac{xu + yv}{u^2 + v^2} + \alpha \frac{yu - xv}{u^2 + v^2} \end{aligned}$$

Note this is just fine except when  $u^2 + v^2 = 0$ ; that is, when  $u = v = 0$ . We may thus divide by any complex number except  $0 = (0,0)$ .

One final note in all this. Almost everyone in the world except an electrical engineer uses the letter  $i$  to denote the complex number we have called  $\alpha$ . We shall accordingly use  $i$  rather than  $\alpha$  to stand for the number  $(0,1)$ .

## Exercises

1. Find the following complex numbers in the form  $x + iy$ :

a)  $(4 - 7i)(-2 + 3i)$

b)  $(1 - i)^3$

b)  $\frac{(5+2i)}{(1+i)}$

c)  $\frac{1}{i}$

2. Find all complex  $z = (x,y)$  such that

$$z^2 + z + 1 = 0$$

3. Prove that if  $wz = 0$ , then  $w = 0$  or  $z = 0$ .

**1.2. Geometry.** We now have this collection of all ordered pairs of real numbers, and so there is an uncontrollable urge to plot them on the usual coordinate axes. We see at once then there is a one-to-one correspondence between the complex numbers and the points in the plane. In the usual way, we can think of the sum of two complex numbers, the point in the plane corresponding to  $z + w$  is the diagonal of the parallelogram having  $z$  and  $w$  as sides:

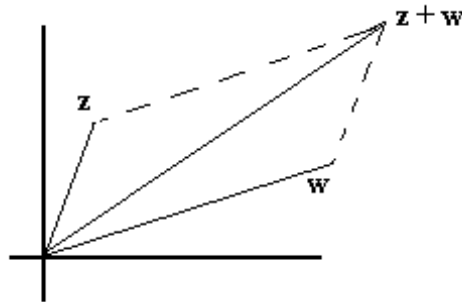

We shall postpone until the next section the geometric interpretation of the product of two complex numbers.

The **modulus** of a complex number  $z = x + iy$  is defined to be the nonnegative real number  $\sqrt{x^2 + y^2}$ , which is, of course, the length of the vector interpretation of  $z$ . This modulus is traditionally denoted  $|z|$ , and is sometimes called the **length** of  $z$ . Note that  $|(x, 0)| = \sqrt{x^2} = |x|$ , and so  $|\cdot|$  is an excellent choice of notation for the modulus.

The **conjugate**  $\bar{z}$  of a complex number  $z = x + iy$  is defined by  $\bar{z} = x - iy$ . Thus  $|z|^2 = z\bar{z}$ . Geometrically, the conjugate of  $z$  is simply the reflection of  $z$  in the horizontal axis:

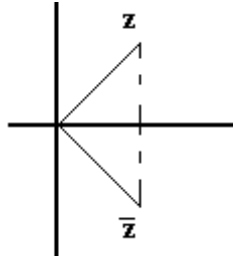

Observe that if  $z = x + iy$  and  $w = u + iv$ , then

$$\begin{aligned} \overline{(z + w)} &= (x + u) - i(y + v) \\ &= (x - iy) + (u - iv) \\ &= \bar{z} + \bar{w}. \end{aligned}$$

In other words, the conjugate of the sum is the sum of the conjugates. It is also true that  $\overline{z\bar{w}} = \bar{z}w$ . If  $z = x + iy$ , then  $x$  is called the **real part** of  $z$ , and  $y$  is called the **imaginary part** of  $z$ . These are usually denoted  $\operatorname{Re}z$  and  $\operatorname{Im}z$ , respectively. Observe then that  $z + \bar{z} = 2\operatorname{Re}z$  and  $z - \bar{z} = 2i\operatorname{Im}z$ .

Now, for any two complex numbers  $z$  and  $w$  consider

$$\begin{aligned} |z + w|^2 &= (z + w)\overline{(z + w)} = (z + w)(\bar{z} + \bar{w}) \\ &= z\bar{z} + (w\bar{z} + \bar{w}z) + w\bar{w} \\ &= |z|^2 + 2\operatorname{Re}(w\bar{z}) + |w|^2 \\ &\leq |z|^2 + 2|z||w| + |w|^2 = (|z| + |w|)^2 \end{aligned}$$

In other words,

$$|z + w| \leq |z| + |w|$$

the so-called **triangle inequality**. (This inequality is an obvious geometric fact—can you guess why it is called the *triangle inequality*?)

### Exercises

4. a) Prove that for any two complex numbers,  $\overline{z\bar{w}} = \bar{z}w$ .

b) Prove that  $\overline{\left(\frac{z}{w}\right)} = \frac{\bar{z}}{\bar{w}}$ .

c) Prove that  $||z| - |w|| \leq |z - w|$ .

5. Prove that  $|zw| = |z||w|$  and that  $\left|\frac{z}{w}\right| = \frac{|z|}{|w|}$ .



6. Sketch the set of points satisfying

a)  $|z - 2 + 3i| = 2$

b)  $|z + 2i| \leq 1$

c)  $\operatorname{Re}(\bar{z} + i) = 4$

d)  $|z - 1 + 2i| = |z + 3 + i|$

e)  $|z + 1| + |z - 1| = 4$

f)  $|z + 1| - |z - 1| = 4$

**1.3. Polar coordinates.** Now let's look at polar coordinates  $(r, \theta)$  of complex numbers. Then we may write  $z = r(\cos \theta + i \sin \theta)$ . In complex analysis, we do not allow  $r$  to be negative; thus  $r$  is simply the modulus of  $z$ . The number  $\theta$  is called an **argument** of  $z$ , and there are, of course, many different possibilities for  $\theta$ . Thus a complex number has an infinite number of arguments, any two of which differ by an integral multiple of  $2\pi$ . We usually write  $\theta = \arg z$ . The **principal argument** of  $z$  is the unique argument that lies on the interval  $(-\pi, \pi]$ .

**Example.** For  $1 - i$ , we have

$$\begin{aligned} 1 - i &= \sqrt{2} \left( \cos\left(\frac{7\pi}{4}\right) + i \sin\left(\frac{7\pi}{4}\right) \right) \\ &= \sqrt{2} \left( \cos\left(-\frac{\pi}{4}\right) + i \sin\left(-\frac{\pi}{4}\right) \right) \\ &= \sqrt{2} \left( \cos\left(\frac{399\pi}{4}\right) + i \sin\left(\frac{399\pi}{4}\right) \right) \end{aligned}$$

*etc., etc., etc.* Each of the numbers  $\frac{7\pi}{4}$ ,  $-\frac{\pi}{4}$ , and  $\frac{399\pi}{4}$  is an argument of  $1 - i$ , but the principal argument is  $-\frac{\pi}{4}$ .

Suppose  $z = r(\cos \theta + i \sin \theta)$  and  $w = s(\cos \xi + i \sin \xi)$ . Then

$$\begin{aligned} zw &= r(\cos \theta + i \sin \theta)s(\cos \xi + i \sin \xi) \\ &= rs[(\cos \theta \cos \xi - \sin \theta \sin \xi) + i(\sin \theta \cos \xi + \sin \xi \cos \theta)] \\ &= rs(\cos(\theta + \xi) + i \sin(\theta + \xi)) \end{aligned}$$

We have the nice result that the product of two complex numbers is the complex number whose modulus is the product of the moduli of the two factors and an argument is the sum of arguments of the factors. A picture:

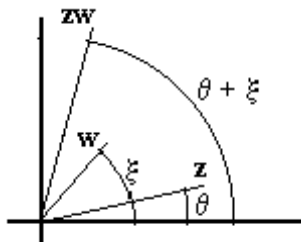

We now define  $\exp(i\theta)$ , or  $e^{i\theta}$  by

$$e^{i\theta} = \cos \theta + i \sin \theta$$

We shall see later as the drama of the term unfolds that this very suggestive notation is an excellent choice. Now, we have in polar form

$$z = re^{i\theta},$$

where  $r = |z|$  and  $\theta$  is any argument of  $z$ . Observe we have just shown that

$$e^{i\theta} e^{i\xi} = e^{i(\theta+\xi)}.$$

It follows from this that  $e^{i\theta} e^{-i\theta} = 1$ . Thus

$$\frac{1}{e^{i\theta}} = e^{-i\theta}$$

It is easy to see that

$$\frac{z}{w} = \frac{re^{i\theta}}{se^{i\xi}} = \frac{r}{s} (\cos(\theta - \xi) + i \sin(\theta - \xi))$$

## Exercises

7. Write in polar form  $re^{i\theta}$ :

- |                    |            |
|--------------------|------------|
| a) $i$             | b) $1 + i$ |
| c) $-2$            | d) $-3i$   |
| e) $\sqrt{3} + 3i$ |            |

8. Write in rectangular form—no decimal approximations, no trig functions:

- |                   |                           |
|-------------------|---------------------------|
| a) $2e^{i3\pi}$   | b) $e^{i100\pi}$          |
| c) $10e^{i\pi/6}$ | d) $\sqrt{2} e^{i5\pi/4}$ |

9. a) Find a polar form of  $(1 + i)(1 + i\sqrt{3})$ .  
b) Use the result of a) to find  $\cos\left(\frac{7\pi}{12}\right)$  and  $\sin\left(\frac{7\pi}{12}\right)$ .

10. Find the rectangular form of  $(-1 + i)^{100}$ .

**11.** Find all  $z$  such that  $z^3 = 1$ . (Again, rectangular form, no trig functions.)

**12.** Find all  $z$  such that  $z^4 = 16i$ . (Rectangular form, *etc.*)

## Chapter Two

# Complex Functions

**2.1. Functions of a real variable.** A function  $\gamma : I \rightarrow \mathbf{C}$  from a set  $I$  of reals into the complex numbers  $\mathbf{C}$  is actually a familiar concept from elementary calculus. It is simply a function from a subset of the reals into the plane, what we sometimes call a vector-valued function. Assuming the function  $\gamma$  is nice, it provides a vector, or parametric, description of a curve. Thus, the set of all  $\{\gamma(t) : \gamma(t) = e^{it} = \cos t + i \sin t = (\cos t, \sin t), 0 \leq t \leq 2\pi\}$  is the circle of radius one, centered at the origin.

We also already know about the derivatives of such functions. If  $\gamma(t) = x(t) + iy(t)$ , then the derivative of  $\gamma$  is simply  $\gamma'(t) = x'(t) + iy'(t)$ , interpreted as a vector in the plane, it is tangent to the curve described by  $\gamma$  at the point  $\gamma(t)$ .

**Example.** Let  $\gamma(t) = t + it^2$ ,  $-1 \leq t \leq 1$ . One easily sees that this function describes that part of the curve  $y = x^2$  between  $x = -1$  and  $x = 1$ :

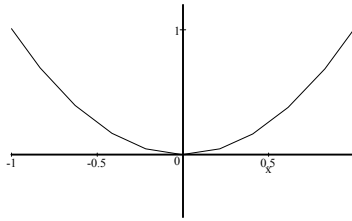

**Another example.** Suppose there is a body of mass  $M$  "fixed" at the origin—perhaps the sun—and there is a body of mass  $m$  which is free to move—perhaps a planet. Let the location of this second body at time  $t$  be given by the complex-valued function  $z(t)$ . We assume the only force on this mass is the gravitational force of the fixed body. This force  $f$  is thus

$$f = \frac{GMm}{|z(t)|^2} \left( -\frac{z(t)}{|z(t)|} \right)$$

where  $G$  is the universal gravitational constant. Sir Isaac Newton tells us that

$$mz''(t) = f = \frac{GMm}{|z(t)|^2} \left( -\frac{z(t)}{|z(t)|} \right)$$

Hence,

$$z'' = -\frac{GM}{|z|^3}z$$

Next, let's write this in polar form,  $z = re^{i\theta}$ :

$$\frac{d^2}{dt^2}(re^{i\theta}) = -\frac{k}{r^2}e^{i\theta}$$

where we have written  $GM = k$ . Now, let's see what we have.

$$\frac{d}{dt}(re^{i\theta}) = r\frac{d}{dt}(e^{i\theta}) + \frac{dr}{dt}e^{i\theta}$$

Now,

$$\begin{aligned}\frac{d}{dt}(e^{i\theta}) &= \frac{d}{dt}(\cos\theta + i\sin\theta) \\ &= (-\sin\theta + i\cos\theta)\frac{d\theta}{dt} \\ &= i(\cos\theta + i\sin\theta)\frac{d\theta}{dt} \\ &= i\frac{d\theta}{dt}e^{i\theta}.\end{aligned}$$

(Additional evidence that our notation  $e^{i\theta} = \cos\theta + i\sin\theta$  is reasonable.)

Thus,

$$\begin{aligned}\frac{d}{dt}(re^{i\theta}) &= r\frac{d}{dt}(e^{i\theta}) + \frac{dr}{dt}e^{i\theta} \\ &= r\left(i\frac{d\theta}{dt}e^{i\theta}\right) + \frac{dr}{dt}e^{i\theta} \\ &= \left(\frac{dr}{dt} + ir\frac{d\theta}{dt}\right)e^{i\theta}.\end{aligned}$$

Now,

$$\begin{aligned}\frac{d^2}{dt^2}(re^{i\theta}) &= \left( \frac{d^2r}{dt^2} + i \frac{dr}{dt} \frac{d\theta}{dt} + ir \frac{d^2\theta}{dt^2} \right) e^{i\theta} + \\ &\quad \left( \frac{dr}{dt} + ir \frac{d\theta}{dt} \right) i \frac{d\theta}{dt} e^{i\theta} \\ &= \left[ \left( \frac{d^2r}{dt^2} - r \left( \frac{d\theta}{dt} \right)^2 \right) + i \left( r \frac{d^2\theta}{dt^2} + 2 \frac{dr}{dt} \frac{d\theta}{dt} \right) \right] e^{i\theta}\end{aligned}$$

Now, the equation  $\frac{d^2}{dt^2}(re^{i\theta}) = -\frac{k}{r^2}e^{i\theta}$  becomes

$$\left( \frac{d^2r}{dt^2} - r \left( \frac{d\theta}{dt} \right)^2 \right) + i \left( r \frac{d^2\theta}{dt^2} + 2 \frac{dr}{dt} \frac{d\theta}{dt} \right) = -\frac{k}{r^2}.$$

This gives us the two equations

$$\frac{d^2r}{dt^2} - r \left( \frac{d\theta}{dt} \right)^2 = -\frac{k}{r^2},$$

and,

$$r \frac{d^2\theta}{dt^2} + 2 \frac{dr}{dt} \frac{d\theta}{dt} = 0.$$

Multiply by  $r$  and this second equation becomes

$$\frac{d}{dt} \left( r^2 \frac{d\theta}{dt} \right) = 0.$$

This tells us that

$$\alpha = r^2 \frac{d\theta}{dt}$$

is a constant. (This constant  $\alpha$  is called the **angular momentum**.) This result allows us to get rid of  $\frac{d\theta}{dt}$  in the first of the two differential equations above:

$$\frac{d^2r}{dt^2} - r \left( \frac{\alpha}{r^2} \right)^2 = -\frac{k}{r^2}$$

or,

$$\frac{d^2r}{dt^2} - \frac{\alpha^2}{r^3} = -\frac{k}{r^2}.$$

Although this now involves only the one unknown function  $r$ , as it stands it is tough to solve. Let's change variables and think of  $r$  as a function of  $\theta$ . Let's also write things in terms of the function  $s = \frac{1}{r}$ . Then,

$$\frac{d}{dt} = \frac{d\theta}{dt} \frac{d}{d\theta} = \frac{\alpha}{r^2} \frac{d}{d\theta}.$$

Hence,

$$\frac{dr}{dt} = \frac{\alpha}{r^2} \frac{dr}{d\theta} = -\alpha \frac{ds}{d\theta},$$

and so

$$\begin{aligned} \frac{d^2r}{dt^2} &= \frac{d}{dt} \left( -\alpha \frac{ds}{d\theta} \right) = \alpha s^2 \frac{d}{d\theta} \left( -\alpha \frac{ds}{d\theta} \right) \\ &= -\alpha^2 s^2 \frac{d^2s}{d\theta^2}, \end{aligned}$$

and our differential equation looks like

$$\frac{d^2r}{dt^2} - \frac{\alpha^2}{r^3} = -\alpha^2 s^2 \frac{d^2s}{d\theta^2} - \alpha^2 s^3 = -ks^2,$$

or,

$$\frac{d^2s}{d\theta^2} + s = \frac{k}{\alpha^2}.$$

This one is easy. From high school differential equations class, we remember that

$$s = \frac{1}{r} = A \cos(\theta + \varphi) + \frac{k}{\alpha^2},$$

where  $A$  and  $\varphi$  are constants which depend on the initial conditions. At long last,

$$r = \frac{\alpha^2/k}{1 + \varepsilon \cos(\theta + \varphi)},$$

where we have set  $\varepsilon = A\alpha^2/k$ . The graph of this equation is, of course, a conic section of eccentricity  $\varepsilon$ .

## Exercises

1. a) What curve is described by the function  $\gamma(t) = (3t + 4) + i(t - 6)$ ,  $0 \leq t \leq 1$  ?  
 b) Suppose  $z$  and  $w$  are complex numbers. What is the curve described by  $\gamma(t) = (1 - t)w + tz$ ,  $0 \leq t \leq 1$  ?
2. Find a function  $\gamma$  that describes that part of the curve  $y = 4x^3 + 1$  between  $x = 0$  and  $x = 10$ .
3. Find a function  $\gamma$  that describes the circle of radius 2 centered at  $z = 3 - 2i$ .
4. Note that in the discussion of the motion of a body in a central gravitational force field, it was assumed that the angular momentum  $\alpha$  is nonzero. Explain what happens in case  $\alpha = 0$ .

**2.2 Functions of a complex variable.** The real excitement begins when we consider function  $f : D \rightarrow \mathbf{C}$  in which the domain  $D$  is a subset of the complex numbers. In some sense, these too are familiar to us from elementary calculus—they are simply functions from a subset of the plane into the plane:

$$f(z) = f(x, y) = u(x, y) + iv(x, y) = (u(x, y), v(x, y))$$

Thus  $f(z) = z^2$  looks like  $f(z) = z^2 = (x + iy)^2 = x^2 - y^2 + 2xyi$ . In other words,  $u(x, y) = x^2 - y^2$  and  $v(x, y) = 2xy$ . The complex perspective, as we shall see, generally provides richer and more profitable insights into these functions.

The definition of the **limit** of a function  $f$  at a point  $z = z_0$  is essentially the same as that which we learned in elementary calculus:

$$\lim_{z \rightarrow z_0} f(z) = L$$

means that given an  $\varepsilon > 0$ , there is a  $\delta$  so that  $|f(z) - L| < \varepsilon$  whenever  $0 < |z - z_0| < \delta$ . As you could guess, we say that  $f$  is **continuous** at  $z_0$  if it is true that  $\lim_{z \rightarrow z_0} f(z) = f(z_0)$ . If  $f$  is continuous at each point of its domain, we say simply that  $f$  is **continuous**.

Suppose both  $\lim_{z \rightarrow z_0} f(z)$  and  $\lim_{z \rightarrow z_0} g(z)$  exist. Then the following properties are easy to establish:



$$\lim_{z \rightarrow z_0} [f(z) \pm g(z)] = \lim_{z \rightarrow z_0} f(z) \pm \lim_{z \rightarrow z_0} g(z)$$

$$\lim_{z \rightarrow z_0} f(z)g(z) = \lim_{z \rightarrow z_0} f(z) \lim_{z \rightarrow z_0} g(z)$$

and,

$$\lim_{z \rightarrow z_0} \frac{f(z)}{g(z)} = \frac{\lim_{z \rightarrow z_0} f(z)}{\lim_{z \rightarrow z_0} g(z)}$$

provided, of course, that  $\lim_{z \rightarrow z_0} g(z) \neq 0$ .

It now follows at once from these properties that the sum, difference, product, and quotient of two functions continuous at  $z_0$  are also continuous at  $z_0$ . (We must, as usual, except the dreaded 0 in the denominator.)

It should not be too difficult to convince yourself that if  $z = (x, y)$ ,  $z_0 = (x_0, y_0)$ , and  $f(z) = u(x, y) + iv(x, y)$ , then

$$\lim_{z \rightarrow z_0} f(z) = \lim_{(x, y) \rightarrow (x_0, y_0)} u(x, y) + i \lim_{(x, y) \rightarrow (x_0, y_0)} v(x, y)$$

Thus  $f$  is continuous at  $z_0 = (x_0, y_0)$  precisely when  $u$  and  $v$  are.

Our next step is the definition of the derivative of a complex function  $f$ . It is the obvious thing. Suppose  $f$  is a function and  $z_0$  is an interior point of the domain of  $f$ . The **derivative**  $f'(z_0)$  of  $f$  is

$$f'(z_0) = \lim_{z \rightarrow z_0} \frac{f(z) - f(z_0)}{z - z_0}$$

### Example

Suppose  $f(z) = z^2$ . Then, letting  $\Delta z = z - z_0$ , we have

$$\begin{aligned}
\lim_{z \rightarrow z_0} \frac{f(z) - f(z_0)}{z - z_0} &= \lim_{\Delta z \rightarrow 0} \frac{f(z_0 + \Delta z) - f(z_0)}{\Delta z} \\
&= \lim_{\Delta z \rightarrow 0} \frac{(z_0 + \Delta z)^2 - z_0^2}{\Delta z} \\
&= \lim_{\Delta z \rightarrow 0} \frac{2z_0\Delta z + (\Delta z)^2}{\Delta z} \\
&= \lim_{\Delta z \rightarrow 0} (2z_0 + \Delta z) \\
&= 2z_0
\end{aligned}$$

No surprise here—the function  $f(z) = z^2$  has a derivative at every  $z$ , and it's simply  $2z$ .

### Another Example

Let  $f(z) = z\bar{z}$ . Then,

$$\begin{aligned}
\lim_{\Delta z \rightarrow 0} \frac{f(z_0 + \Delta z) - f(z_0)}{\Delta z} &= \lim_{\Delta z \rightarrow 0} \frac{(z_0 + \Delta z)\overline{(z_0 + \Delta z)} - z_0\bar{z}_0}{\Delta z} \\
&= \lim_{\Delta z \rightarrow 0} \frac{z_0\bar{\Delta z} + \bar{z}_0\Delta z + \Delta z\bar{\Delta z}}{\Delta z} \\
&= \lim_{\Delta z \rightarrow 0} \left( \bar{z}_0 + \bar{\Delta z} + z_0 \frac{\bar{\Delta z}}{\Delta z} \right)
\end{aligned}$$

Suppose this limit exists, and choose  $\Delta z = (\Delta x, 0)$ . Then,

$$\begin{aligned}
\lim_{\Delta z \rightarrow 0} \left( \bar{z}_0 + \bar{\Delta z} + z_0 \frac{\bar{\Delta z}}{\Delta z} \right) &= \lim_{\Delta x \rightarrow 0} \left( \bar{z}_0 + \Delta x + z_0 \frac{\Delta x}{\Delta x} \right) \\
&= \bar{z}_0 + z_0
\end{aligned}$$

Now, choose  $\Delta z = (0, \Delta y)$ . Then,

$$\begin{aligned}
\lim_{\Delta z \rightarrow 0} \left( \bar{z}_0 + \bar{\Delta z} + z_0 \frac{\bar{\Delta z}}{\Delta z} \right) &= \lim_{\Delta y \rightarrow 0} \left( \bar{z}_0 - i\Delta y - z_0 \frac{i\Delta y}{i\Delta y} \right) \\
&= \bar{z}_0 - z_0
\end{aligned}$$

Thus, we must have  $\bar{z}_0 + z_0 = \bar{z}_0 - z_0$ , or  $z_0 = 0$ . In other words, there is no chance of this limit's existing, except possibly at  $z_0 = 0$ . So, this function does not have a derivative at most places.

Now, take another look at the first of these two examples. It looks exactly like what you

did in Mrs. Turner's 3<sup>rd</sup> grade calculus class for plain old real-valued functions. Meditate on this and you will be convinced that all the "usual" results for real-valued functions also hold for these new complex functions: the derivative of a constant is zero, the derivative of the sum of two functions is the sum of the derivatives, the "product" and "quotient" rules for derivatives are valid, the chain rule for the composition of functions holds, *etc.*, *etc.* For proofs, you need only go back to your elementary calculus book and change  $x$ 's to  $z$ 's.

A bit of jargon is in order. If  $f$  has a derivative at  $z_0$ , we say that  $f$  is **differentiable** at  $z_0$ . If  $f$  is differentiable at every point of a neighborhood of  $z_0$ , we say that  $f$  is **analytic** at  $z_0$ . (A set  $S$  is a **neighborhood** of  $z_0$  if there is a disk  $D = \{z : |z - z_0| < r, r > 0\}$  so that  $D \subset S$ .) If  $f$  is analytic at every point of some set  $S$ , we say that  $f$  is **analytic on  $S$** . A function that is analytic on the set of all complex numbers is said to be an **entire** function.

### Exercises

5. Suppose  $f(z) = 3xy + i(x - y^2)$ . Find  $\lim_{z \rightarrow 3+2i} f(z)$ , or explain carefully why it does not exist.

6. Prove that if  $f$  has a derivative at  $z$ , then  $f$  is continuous at  $z$ .

7. Find all points at which the valued function  $f$  defined by  $f(z) = \bar{z}$  has a derivative.

8. Find all points at which the valued function  $f$  defined by  

$$f(z) = (2 + i)z^3 - iz^2 + 4z - (1 + 7i)$$
has a derivative.

9. Is the function  $f$  given by

$$f(z) = \begin{cases} \frac{(\bar{z})^2}{z} & , z \neq 0 \\ 0 & , z = 0 \end{cases}$$

differentiable at  $z = 0$ ? Explain.

**2.3. Derivatives.** Suppose the function  $f$  given by  $f(z) = u(x, y) + iv(x, y)$  has a derivative at  $z = z_0 = (x_0, y_0)$ . We know this means there is a number  $f'(z_0)$  so that

$$f'(z_0) = \lim_{\Delta z \rightarrow 0} \frac{f(z_0 + \Delta z) - f(z_0)}{\Delta z}.$$

Choose  $\Delta z = (\Delta x, 0) = \Delta x$ . Then,

$$\begin{aligned}
 f'(z_0) &= \lim_{\Delta z \rightarrow 0} \frac{f(z_0 + \Delta z) - f(z_0)}{\Delta z} \\
 &= \lim_{\Delta x \rightarrow 0} \frac{u(x_0 + \Delta x, y_0) + iv(x_0 + \Delta x, y_0) - u(x_0, y_0) - iv(x_0, y_0)}{\Delta x} \\
 &= \lim_{\Delta x \rightarrow 0} \left[ \frac{u(x_0 + \Delta x, y_0) - u(x_0, y_0)}{\Delta x} + i \frac{v(x_0 + \Delta x, y_0) - v(x_0, y_0)}{\Delta x} \right] \\
 &= \frac{\partial u}{\partial x}(x_0, y_0) + i \frac{\partial v}{\partial x}(x_0, y_0)
 \end{aligned}$$

Next, choose  $\Delta z = (0, \Delta y) = i\Delta y$ . Then,

$$\begin{aligned}
 f'(z_0) &= \lim_{\Delta z \rightarrow 0} \frac{f(z_0 + \Delta z) - f(z_0)}{\Delta z} \\
 &= \lim_{\Delta y \rightarrow 0} \frac{u(x_0, y_0 + \Delta y) + iv(x_0, y_0 + \Delta y) - u(x_0, y_0) - iv(x_0, y_0)}{i\Delta y} \\
 &= \lim_{\Delta y \rightarrow 0} \left[ \frac{v(x_0, y_0 + \Delta y) - v(x_0, y_0)}{\Delta y} - i \frac{u(x_0, y_0 + \Delta y) - u(x_0, y_0)}{\Delta y} \right] \\
 &= \frac{\partial v}{\partial y}(x_0, y_0) - i \frac{\partial u}{\partial y}(x_0, y_0)
 \end{aligned}$$

We have two different expressions for the derivative  $f'(z_0)$ , and so

$$\frac{\partial u}{\partial x}(x_0, y_0) + i \frac{\partial v}{\partial x}(x_0, y_0) = \frac{\partial v}{\partial y}(x_0, y_0) - i \frac{\partial u}{\partial y}(x_0, y_0)$$

or,

$$\begin{aligned}
 \frac{\partial u}{\partial x}(x_0, y_0) &= \frac{\partial v}{\partial y}(x_0, y_0), \\
 \frac{\partial u}{\partial y}(x_0, y_0) &= -\frac{\partial v}{\partial x}(x_0, y_0)
 \end{aligned}$$

These equations are called the **Cauchy-Riemann Equations**.

We have shown that if  $f$  has a derivative at a point  $z_0$ , then its real and imaginary parts satisfy these equations. Even more exciting is the fact that if the real and imaginary parts of  $f$  satisfy these equations and if in addition, they have continuous first partial derivatives, then the function  $f$  has a derivative. Specifically, suppose  $u(x, y)$  and  $v(x, y)$  have partial derivatives in a neighborhood of  $z_0 = (x_0, y_0)$ , suppose these derivatives are continuous at  $z_0$ , and suppose

$$\frac{\partial u}{\partial x}(x_0, y_0) = \frac{\partial v}{\partial y}(x_0, y_0),$$

$$\frac{\partial u}{\partial y}(x_0, y_0) = -\frac{\partial v}{\partial x}(x_0, y_0).$$

We shall see that  $f$  is differentiable at  $z_0$ .

$$\frac{f(z_0 + \Delta z) - f(z_0)}{\Delta z}$$

$$= \frac{[u(x_0 + \Delta x, y_0 + \Delta y) - u(x_0, y_0)] + i[v(x_0 + \Delta x, y_0 + \Delta y) - v(x_0, y_0)]}{\Delta x + i\Delta y}.$$

Observe that

$$u(x_0 + \Delta x, y_0 + \Delta y) - u(x_0, y_0) = [u(x_0 + \Delta x, y_0 + \Delta y) - u(x_0, y_0 + \Delta y)] + [u(x_0, y_0 + \Delta y) - u(x_0, y_0)].$$

Thus,

$$u(x_0 + \Delta x, y_0 + \Delta y) - u(x_0, y_0 + \Delta y) = \Delta x \frac{\partial u}{\partial x}(\xi, y_0 + \Delta y),$$

and,

$$\frac{\partial u}{\partial x}(\xi, y_0 + \Delta y) = \frac{\partial u}{\partial x}(x_0, y_0) + \varepsilon_1,$$

where,

$$\lim_{\Delta z \rightarrow 0} \varepsilon_1 = 0.$$

Thus,

$$u(x_0 + \Delta x, y_0 + \Delta y) - u(x_0, y_0 + \Delta y) = \Delta x \left[ \frac{\partial u}{\partial x}(x_0, y_0) + \varepsilon_1 \right].$$

Proceeding similarly, we get

$$\begin{aligned}
& \frac{f(z_0 + \Delta z) - f(z_0)}{\Delta z} \\
&= \frac{[u(x_0 + \Delta x, y_0 + \Delta y) - u(x_0, y_0)] + i[v(x_0 + \Delta x, y_0 + \Delta y) - v(x_0, y_0)]}{\Delta x + i\Delta y} \\
&= \frac{\Delta x \left[ \frac{\partial u}{\partial x}(x_0, y_0) + \varepsilon_1 + i \frac{\partial v}{\partial x}(x_0, y_0) + i\varepsilon_2 \right] + \Delta y \left[ \frac{\partial u}{\partial y}(x_0, y_0) + \varepsilon_3 + i \frac{\partial v}{\partial y}(x_0, y_0) + i\varepsilon_4 \right]}{\Delta x + i\Delta y},
\end{aligned}$$

where  $\varepsilon_i \rightarrow 0$  as  $\Delta z \rightarrow 0$ . Now, unleash the Cauchy-Riemann equations on this quotient and obtain,

$$\begin{aligned}
& \frac{f(z_0 + \Delta z) - f(z_0)}{\Delta z} \\
&= \frac{\Delta x \left[ \frac{\partial u}{\partial x} + i \frac{\partial v}{\partial x} \right] + i\Delta y \left[ \frac{\partial u}{\partial x} + i \frac{\partial v}{\partial x} \right]}{\Delta x + i\Delta y} + \frac{\text{stuff}}{\Delta x + i\Delta y} \\
&= \left[ \frac{\partial u}{\partial x} + i \frac{\partial v}{\partial x} \right] + \frac{\text{stuff}}{\Delta x + i\Delta y}.
\end{aligned}$$

Here,

$$\text{stuff} = \Delta x(\varepsilon_1 + i\varepsilon_2) + \Delta y(\varepsilon_3 + i\varepsilon_4).$$

It's easy to show that

$$\lim_{\Delta z \rightarrow 0} \frac{\text{stuff}}{\Delta z} = 0,$$

and so,

$$\lim_{\Delta z \rightarrow 0} \frac{f(z_0 + \Delta z) - f(z_0)}{\Delta z} = \frac{\partial u}{\partial x} + i \frac{\partial v}{\partial x}.$$

In particular we have, as promised, shown that  $f$  is differentiable at  $z_0$ .

### Example

Let's find all points at which the function  $f$  given by  $f(z) = x^3 + i(1 - y)^3$  is differentiable. Here we have  $u = x^3$  and  $v = (1 - y)^3$ . The Cauchy-Riemann equations thus look like

$$\begin{aligned}
3x^2 &= 3(1 - y)^2, \text{ and} \\
0 &= 0.
\end{aligned}$$

The partial derivatives of  $u$  and  $v$  are nice and continuous everywhere, so  $f$  will be differentiable everywhere the C-R equations are satisfied. That is, everywhere

$$x^2 = (1 - y)^2; \text{ that is, where}$$

$$x = 1 - y, \text{ or } x = -1 + y.$$

This is simply the set of all points on the cross formed by the two straight lines

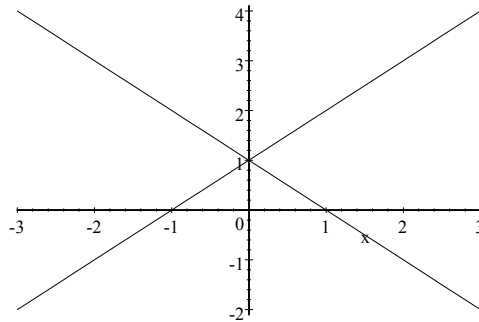

### Exercises

10. At what points is the function  $f$  given by  $f(z) = x^3 + i(1 - y)^3$  analytic? Explain.
11. Do the real and imaginary parts of the function  $f$  in Exercise 9 satisfy the Cauchy-Riemann equations at  $z = 0$ ? What do you make of your answer?
12. Find all points at which  $f(z) = 2y - ix$  is differentiable.
13. Suppose  $f$  is analytic on a connected open set  $D$ , and  $f'(z) = 0$  for all  $z \in D$ . Prove that  $f$  is constant.

14. Find all points at which

$$f(z) = \frac{x}{x^2 + y^2} - i \frac{y}{x^2 + y^2}$$

is differentiable. At what points is  $f$  analytic? Explain.

15. Suppose  $f$  is analytic on the set  $D$ , and suppose  $\operatorname{Re} f$  is constant on  $D$ . Is  $f$  necessarily

constant on  $D$ ? Explain.

**16.** Suppose  $f$  is analytic on the set  $D$ , and suppose  $|f(z)|$  is constant on  $D$ . Is  $f$  necessarily constant on  $D$ ? Explain.



## Chapter Three

# Elementary Functions

**3.1. Introduction.** Complex functions are, of course, quite easy to come by—they are simply ordered pairs of real-valued functions of two variables. We have, however, already seen enough to realize that it is those complex functions that are differentiable that are the most interesting. It was important in our invention of the complex numbers that these new numbers in some sense included the old real numbers—in other words, we extended the reals. We shall find it most useful and profitable to do a similar thing with many of the familiar real functions. That is, we seek complex functions such that when restricted to the reals are familiar real functions. As we have seen, the extension of polynomials and rational functions to complex functions is easy; we simply change  $x$ 's to  $z$ 's. Thus, for instance, the function  $f$  defined by

$$f(z) = \frac{z^2 + z + 1}{z + 1}$$

has a derivative at each point of its domain, and for  $z = x + 0i$ , becomes a familiar real rational function

$$f(x) = \frac{x^2 + x + 1}{x + 1}.$$

What happens with the trigonometric functions, exponentials, logarithms, *etc.*, is not so obvious. Let us begin.

**3.2. The exponential function.** Let the so-called exponential function  $\exp$  be defined by

$$\exp(z) = e^x(\cos y + i \sin y),$$

where, as usual,  $z = x + iy$ . From the Cauchy-Riemann equations, we see at once that this function has a derivative every where—it is an entire function. Moreover,

$$\frac{d}{dz} \exp(z) = \exp(z).$$

Note next that if  $z = x + iy$  and  $w = u + iv$ , then

$$\begin{aligned}
\exp(z + w) &= e^{x+u}[\cos(y + v) + i \sin(y + v)] \\
&= e^x e^y [\cos y \cos v - \sin y \sin v + i(\sin y \cos v + \cos y \sin v)] \\
&= e^x e^y (\cos y + i \sin y)(\cos v + i \sin v) \\
&= \exp(z) \exp(w).
\end{aligned}$$

We thus use the quite reasonable notation  $e^z = \exp(z)$  and observe that we have extended the real exponential  $e^x$  to the complex numbers.

### Example

Recall from elementary circuit analysis that the relation between the voltage drop  $V$  and the current flow  $I$  through a resistor is  $V = RI$ , where  $R$  is the resistance. For an inductor, the relation is  $V = L \frac{dI}{dt}$ , where  $L$  is the inductance; and for a capacitor,  $C \frac{dV}{dt} = I$ , where  $C$  is the capacitance. (The variable  $t$  is, of course, time.) Note that if  $V$  is sinusoidal with a frequency  $\omega$ , then so also is  $I$ . Suppose then that  $V = A \sin(\omega t + \phi)$ . We can write this as  $V = \text{Im}(Ae^{i\phi} e^{i\omega t}) = \text{Im}(Be^{i\omega t})$ , where  $B$  is complex. We know the current  $I$  will have this same form:  $I = \text{Im}(Ce^{i\omega t})$ . The relations between the voltage and the current are linear, and so we can consider complex voltages and currents and use the fact that  $e^{i\omega t} = \cos \omega t + i \sin \omega t$ . We thus assume a more or less fictional complex voltage  $V$ , the imaginary part of which is the actual voltage, and then the actual current will be the imaginary part of the resulting complex current.

What makes this a good idea is the fact that differentiation with respect to time  $t$  becomes simply multiplication by  $i\omega$ :  $\frac{d}{dt} A e^{i\omega t} = i\omega A e^{i\omega t}$ . If  $I = b e^{i\omega t}$ , the above relations between current and voltage become  $V = i\omega L I$  for an inductor, and  $i\omega V C = I$ , or  $V = \frac{I}{i\omega C}$  for a capacitor. Calculus is thereby turned into algebra. To illustrate, suppose we have a simple RLC circuit with a voltage source  $V = a \sin \omega t$ . We let  $E = a e^{i\omega t}$ .

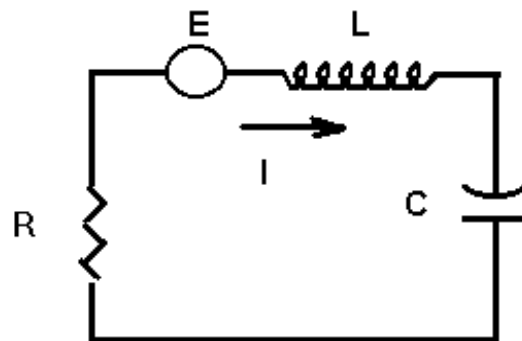

Then the fact that the voltage drop around a closed circuit must be zero (one of Kirchoff's celebrated laws) looks like

$$i\omega LI + \frac{I}{i\omega C} + RI = ae^{i\omega t}, \text{ or}$$

$$i\omega Lb + \frac{b}{i\omega C} + Rb = a$$

Thus,

$$b = \frac{a}{R + i\left(\omega L - \frac{1}{\omega C}\right)}.$$

In polar form,

$$b = \frac{a}{\sqrt{R^2 + \left(\omega L - \frac{1}{\omega C}\right)^2}} e^{i\varphi},$$

where

$$\tan \varphi = \frac{\omega L - \frac{1}{\omega C}}{R}. \quad (R \neq 0)$$

Hence,

$$I = \text{Im}(be^{i\omega t}) = \text{Im}\left(\frac{a}{\sqrt{R^2 + \left(\omega L - \frac{1}{\omega C}\right)^2}} e^{i(\omega t + \varphi)}\right)$$

$$= \frac{a}{\sqrt{R^2 + \left(\omega L - \frac{1}{\omega C}\right)^2}} \sin(\omega t + \varphi)$$

This result is well-known to all, but I hope you are convinced that this algebraic approach afforded us by the use of complex numbers is far easier than solving the differential equation. You should note that this method yields the steady state solution—the transient solution is not necessarily sinusoidal.

### Exercises

1. Show that  $\exp(z + 2\pi i) = \exp(z)$ .

2. Show that  $\frac{\exp(z)}{\exp(w)} = \exp(z - w)$ .

3. Show that  $|\exp(z)| = e^x$ , and  $\arg(\exp(z)) = y + 2k\pi$  for any  $\arg(\exp(z))$  and some

integer  $k$ .

4. Find all  $z$  such that  $\exp(z) = -1$ , or explain why there are none.
5. Find all  $z$  such that  $\exp(z) = 1 + i$ , or explain why there are none.
6. For what complex numbers  $w$  does the equation  $\exp(z) = w$  have solutions? Explain.
7. Find the indicated mesh currents in the network:

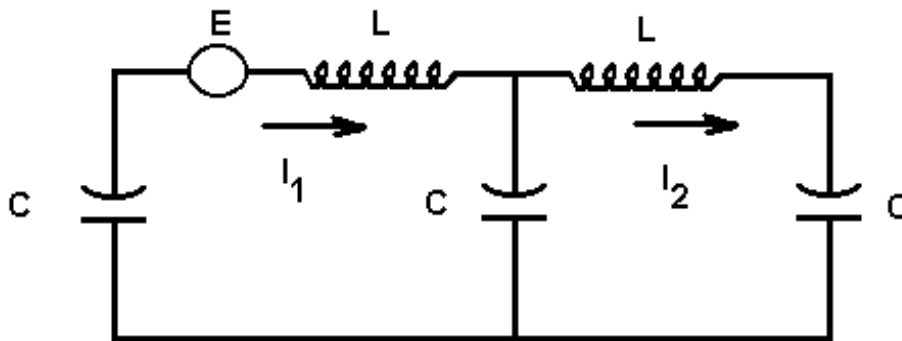

**3.3 Trigonometric functions.** Define the functions cosine and sine as follows:

$$\cos z = \frac{e^{iz} + e^{-iz}}{2},$$
$$\sin z = \frac{e^{iz} - e^{-iz}}{2i}$$

where we are using  $e^z = \exp(z)$ .

First, let's verify that these are honest-to-goodness extensions of the familiar real functions, cosine and sine—otherwise we have chosen very bad names for these complex functions. So, suppose  $z = x + 0i = x$ . Then,

$$e^{ix} = \cos x + i \sin x, \text{ and}$$
$$e^{-ix} = \cos x - i \sin x.$$

Thus,

$$\cos x = \frac{e^{ix} + e^{-ix}}{2},$$

$$\sin x = \frac{e^{ix} - e^{-ix}}{2i},$$

and everything is just fine.

Next, observe that the sine and cosine functions are entire—they are simply linear combinations of the entire functions  $e^{iz}$  and  $e^{-iz}$ . Moreover, we see that

$$\frac{d}{dz} \sin z = \cos z, \text{ and } \frac{d}{dz} \cos z = -\sin z,$$

just as we would hope.

It may not have been clear to you back in elementary calculus what the so-called hyperbolic sine and cosine functions had to do with the ordinary sine and cosine functions. Now perhaps it will be evident. Recall that for real  $t$ ,

$$\sinh t = \frac{e^t - e^{-t}}{2}, \text{ and } \cosh t = \frac{e^t + e^{-t}}{2}.$$

Thus,

$$\sin(it) = \frac{e^{i(it)} - e^{-i(it)}}{2i} = i \frac{e^t - e^{-t}}{2} = i \sinh t.$$

Similarly,

$$\cos(it) = \cosh t.$$

How nice!

Most of the identities you learned in the 3<sup>rd</sup> grade for the real sine and cosine functions are also valid in the general complex case. Let's look at some.

$$\begin{aligned} \sin^2 z + \cos^2 z &= \frac{1}{4} [-(e^{iz} - e^{-iz})^2 + (e^{iz} + e^{-iz})^2] \\ &= \frac{1}{4} [-e^{2iz} + 2e^{iz}e^{-iz} - e^{-2iz} + e^{2iz} + 2e^{iz}e^{-iz} + e^{-2iz}] \\ &= \frac{1}{4} (2 + 2) = 1 \end{aligned}$$

It is also relative straight-forward and easy to show that:

$$\begin{aligned}\sin(z \pm w) &= \sin z \cos w \pm \cos z \sin w, \text{ and} \\ \cos(z \pm w) &= \cos z \cos w \mp \sin z \sin w\end{aligned}$$

Other familiar ones follow from these in the usual elementary school trigonometry fashion.

Let's find the real and imaginary parts of these functions:

$$\begin{aligned}\sin z &= \sin(x + iy) = \sin x \cos(iy) + \cos x \sin(iy) \\ &= \sin x \cosh y + i \cos x \sinh y.\end{aligned}$$

In the same way, we get  $\cos z = \cos x \cosh y - i \sin x \sinh y$ .

### Exercises

8. Show that for all  $z$ ,

$$\text{a) } \sin(z + 2\pi) = \sin z; \quad \text{b) } \cos(z + 2\pi) = \cos z; \quad \text{c) } \sin\left(z + \frac{\pi}{2}\right) = \cos z.$$

9. Show that  $|\sin z|^2 = \sin^2 x + \sinh^2 y$  and  $|\cos z|^2 = \cos^2 x + \sinh^2 y$ .

10. Find all  $z$  such that  $\sin z = 0$ .

11. Find all  $z$  such that  $\cos z = 2$ , or explain why there are none.

**3.4. Logarithms and complex exponents.** In the case of real functions, the logarithm function was simply the inverse of the exponential function. Life is more complicated in the complex case—as we have seen, the complex exponential function is not invertible. There are many solutions to the equation  $e^z = w$ .

If  $z \neq 0$ , we define  $\log z$  by

$$\log z = \ln|z| + i \arg z.$$

There are thus many  $\log z$ 's; one for each argument of  $z$ . The difference between any two of these is thus an integral multiple of  $2\pi i$ . First, for any value of  $\log z$  we have

$$e^{\log z} = e^{\ln|z| + i \arg z} = e^{\ln|z|} e^{i \arg z} = z.$$

This is familiar. But next there is a slight complication:

$$\begin{aligned} \log(e^z) &= \ln e^x + i \arg e^z = x + (y + 2k\pi)i \\ &= z + 2k\pi i, \end{aligned}$$

where  $k$  is an integer. We also have

$$\begin{aligned} \log(zw) &= \ln(|z||w|) + i \arg(zw) \\ &= \ln|z| + i \arg z + \ln|w| + i \arg w + 2k\pi i \\ &= \log z + \log w + 2k\pi i \end{aligned}$$

for some integer  $k$ .

There is defined a function, called the **principal logarithm**, or **principal branch** of the logarithm, function, given by

$$\text{Log } z = \ln|z| + i \text{Arg } z,$$

where  $\text{Arg } z$  is the principal argument of  $z$ . Observe that for any  $\log z$ , it is true that  $\log z = \text{Log } z + 2k\pi i$  for some integer  $k$  which depends on  $z$ . This new function is an extension of the real logarithm function:

$$\text{Log } x = \ln x + i \text{Arg } x = \ln x.$$

This function is analytic at a lot of places. First, note that it is not defined at  $z = 0$ , and is not continuous anywhere on the negative real axis ( $z = x + 0i$ , where  $x < 0$ ). So, let's suppose  $z_0 = x_0 + iy_0$ , where  $z_0$  is not zero or on the negative real axis, and see about a derivative of  $\text{Log } z$  :

$$\lim_{z \rightarrow z_0} \frac{\text{Log } z - \text{Log } z_0}{z - z_0} = \lim_{z \rightarrow z_0} \frac{\text{Log } z - \text{Log } z_0}{e^{\text{Log } z} - e^{\text{Log } z_0}}.$$

Now if we let  $w = \text{Log } z$  and  $w_0 = \text{Log } z_0$ , and notice that  $w \rightarrow w_0$  as  $z \rightarrow z_0$ , this becomes

$$\begin{aligned} \lim_{z \rightarrow z_0} \frac{\text{Log } z - \text{Log } z_0}{z - z_0} &= \lim_{w \rightarrow w_0} \frac{w - w_0}{e^w - e^{w_0}} \\ &= \frac{1}{e^{w_0}} = \frac{1}{z_0} \end{aligned}$$

Thus, Log is differentiable at  $z_0$ , and its derivative is  $\frac{1}{z_0}$ .

We are now ready to give meaning to  $z^c$ , where  $c$  is a complex number. We do the obvious and define

$$z^c = e^{c \log z}.$$

There are many values of  $\log z$ , and so there can be many values of  $z^c$ . As one might guess,  $e^{c \text{Log } z}$  is called the **principal value** of  $z^c$ .

Note that we are faced with two different definitions of  $z^c$  in case  $c$  is an integer. Let's see if we have anything to unlearn. Suppose  $c$  is simply an integer,  $c = n$ . Then

$$\begin{aligned} z^n &= e^{n \log z} = e^{k(\text{Log } z + 2k\pi i)} \\ &= e^{n \text{Log } z} e^{2kn\pi i} = e^{n \text{Log } z} \end{aligned}$$

There is thus just one value of  $z^n$ , and it is exactly what it should be:  $e^{n \text{Log } z} = |z|^n e^{in \arg z}$ . It is easy to verify that in case  $c$  is a rational number,  $z^c$  is also exactly what it should be.

Far more serious is the fact that we are faced with conflicting definitions of  $z^c$  in case  $z = e$ . In the above discussion, we have assumed that  $e^z$  stands for  $\exp(z)$ . Now we have a definition for  $e^z$  that implies that  $e^z$  can have many values. For instance, if someone runs at you in the night and hands you a note with  $e^{1/2}$  written on it, how do you know whether this means  $\exp(1/2)$  or the two values  $\sqrt{e}$  and  $-\sqrt{e}$ ? Strictly speaking, you do not know. This ambiguity could be avoided, of course, by always using the notation  $\exp(z)$  for  $e^x e^{iy}$ , but almost everybody in the world uses  $e^z$  with the understanding that this is  $\exp(z)$ , or equivalently, the principal value of  $e^z$ . This will be our practice.

### Exercises

12. Is the collection of all values of  $\log(i^{1/2})$  the same as the collection of all values of  $\frac{1}{2} \log i$ ? Explain.
13. Is the collection of all values of  $\log(i^2)$  the same as the collection of all values of  $2 \log i$ ? Explain.





## Chapter Four

### Integration

**4.1. Introduction.** If  $\gamma : D \rightarrow \mathbf{C}$  is simply a function on a real interval  $D = [\alpha, \beta]$ , then the integral  $\int_{\alpha}^{\beta} \gamma(t) dt$  is, of course, simply an ordered pair of everyday 3<sup>rd</sup> grade calculus integrals:

$$\int_{\alpha}^{\beta} \gamma(t) dt = \int_{\alpha}^{\beta} x(t) dt + i \int_{\alpha}^{\beta} y(t) dt,$$

where  $\gamma(t) = x(t) + iy(t)$ . Thus, for example,

$$\int_0^1 [(t^2 + 1) + it^3] dt = \frac{4}{3} + \frac{i}{4}.$$

Nothing really new here. The excitement begins when we consider the idea of an integral of an honest-to-goodness complex function  $f : D \rightarrow \mathbf{C}$ , where  $D$  is a subset of the complex plane. Let's define the integral of such things; it is pretty much a straight-forward extension to two dimensions of what we did in one dimension back in Mrs. Turner's class.

Suppose  $f$  is a complex-valued function on a subset of the complex plane and suppose  $a$  and  $b$  are *complex* numbers in the domain of  $f$ . In one dimension, there is just one way to get from one number to the other; here we must also specify a path from  $a$  to  $b$ . Let  $C$  be a path from  $a$  to  $b$ , and we must also require that  $C$  be a subset of the domain of  $f$ .

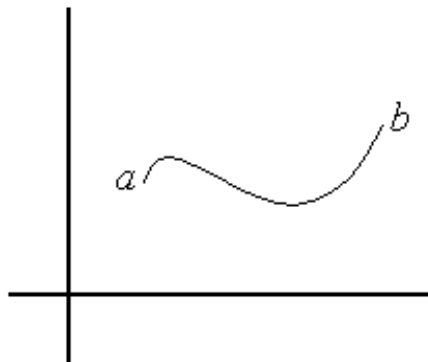

(Note we do not even require that  $a \neq b$ ; but in case  $a = b$ , we must specify an *orientation* for the closed path  $C$ .) Next, let  $P$  be a **partition** of the curve; that is,  $P = \{z_0, z_1, z_2, \dots, z_n\}$  is a finite subset of  $C$ , such that  $a = z_0$ ,  $b = z_n$ , and such that  $z_j$  comes immediately after  $z_{j-1}$  as we travel along  $C$  from  $a$  to  $b$ .

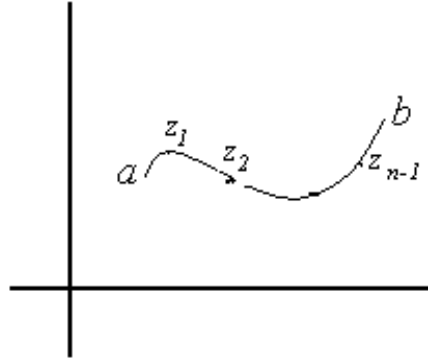

A Riemann sum associated with the partition  $P$  is just what it is in the real case:

$$S(P) = \sum_{j=1}^n f(z_j^*) \Delta z_j,$$

where  $z_j^*$  is a point on the arc between  $z_{j-1}$  and  $z_j$ , and  $\Delta z_j = z_j - z_{j-1}$ . (Note that for a given partition  $P$ , there are many  $S(P)$ —depending on how the points  $z_j^*$  are chosen.) If there is a number  $L$  so that given any  $\varepsilon > 0$ , there is a partition  $P_\varepsilon$  of  $C$  such that

$$|S(P) - L| < \varepsilon$$

whenever  $P \supset P_\varepsilon$ , then  $f$  is said to be integrable on  $C$  and the number  $L$  is called the **integral of  $f$**  on  $C$ . This number  $L$  is usually written  $\int_C f(z) dz$ .

Some properties of integrals are more or less evident from looking at Riemann sums:

$$\int_C c f(z) dz = c \int_C f(z) dz$$

for any complex constant  $c$ .

$$\int_C (f(z) + g(z)) dz = \int_C f(z) dz + \int_C g(z) dz$$

**4.2 Evaluating integrals.** Now, how on Earth do we ever find such an integral? Let  $\gamma : [\alpha, \beta] \rightarrow \mathbf{C}$  be a complex description of the curve  $C$ . We partition  $C$  by partitioning the interval  $[\alpha, \beta]$  in the usual way:  $\alpha = t_0 < t_1 < t_2 < \dots < t_n = \beta$ . Then  $\{a = \gamma(\alpha), \gamma(t_1), \gamma(t_2), \dots, \gamma(\beta) = b\}$  is partition of  $C$ . (Recall we assume that  $\gamma'(t) \neq 0$  for a complex description of a curve  $C$ .) A corresponding Riemann sum looks like

$$S(P) = \sum_{j=1}^n f(\gamma(t_j^*)) (\gamma(t_j) - \gamma(t_{j-1})).$$

We have chosen the points  $z_j^* = \gamma(t_j^*)$ , where  $t_{j-1} \leq t_j^* \leq t_j$ . Next, multiply each term in the sum by 1 in disguise:

$$S(P) = \sum_{j=1}^n f(\gamma(t_j^*)) \left( \frac{\gamma(t_j) - \gamma(t_{j-1})}{t_j - t_{j-1}} \right) (t_j - t_{j-1}).$$

I hope it is now reasonably convincing that "in the limit", we have

$$\int_C f(z) dz = \int_{\alpha}^{\beta} f(\gamma(t)) \gamma'(t) dt.$$

(We are, of course, assuming that the derivative  $\gamma'$  exists.)

### Example

We shall find the integral of  $f(z) = (x^2 + y) + i(xy)$  from  $a = 0$  to  $b = 1 + i$  along three different paths, or **contours**, as some call them.

First, let  $C_1$  be the part of the parabola  $y = x^2$  connecting the two points. A complex description of  $C_1$  is  $\gamma_1(t) = t + it^2, 0 \leq t \leq 1$ :

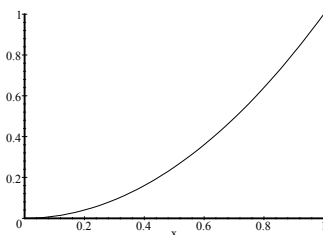

Now,  $\gamma_1'(t) = 1 + 2ti$ , and  $f(\gamma_1(t)) = (t^2 + t^2) + itt^2 = 2t^2 + it^3$ . Hence,

$$\begin{aligned} \int_{C_1} f(z)dz &= \int_0^1 f(\gamma_1(t))\gamma_1'(t)dt \\ &= \int_0^1 (2t^2 + it^3)(1 + 2ti)dt \\ &= \int_0^1 (2t^2 - 2t^4 + 5t^3i)dt \\ &= \frac{4}{15} + \frac{5}{4}i \end{aligned}$$

Next, let's integrate along the straight line segment  $C_2$  joining 0 and  $1 + i$ .

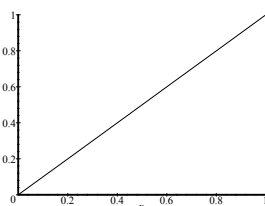

Here we have  $\gamma_2(t) = t + it$ ,  $0 \leq t \leq 1$ . Thus,  $\gamma_2'(t) = 1 + i$ , and our integral looks like

$$\begin{aligned}
\int_{C_2} f(z) dz &= \int_0^1 f(\gamma_2(t)) \gamma_2'(t) dt \\
&= \int_0^1 [(t^2 + t) + it^2](1 + i) dt \\
&= \int_0^1 [t + i(t + 2t^2)] dt \\
&= \frac{1}{2} + \frac{7}{6}i
\end{aligned}$$

Finally, let's integrate along  $C_3$ , the path consisting of the line segment from 0 to 1 together with the segment from 1 to  $1 + i$ .

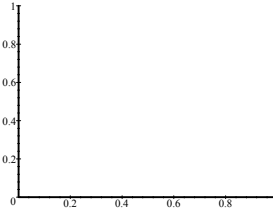

We shall do this in two parts:  $C_{31}$ , the line from 0 to 1 ; and  $C_{32}$ , the line from 1 to  $1 + i$ . Then we have

$$\int_{C_3} f(z) dz = \int_{C_{31}} f(z) dz + \int_{C_{32}} f(z) dz.$$

For  $C_{31}$  we have  $\gamma(t) = t, 0 \leq t \leq 1$ . Hence,

$$\int_{C_{31}} f(z) dz = \int_0^1 dt = \frac{1}{3}.$$

For  $C_{32}$  we have  $\gamma(t) = 1 + it, 0 \leq t \leq 1$ . Hence,

$$\int_{C_{32}} f(z) dz = \int_0^1 (1 + t + it) it dt = -\frac{1}{3} + \frac{5}{6}i.$$

Thus,

$$\begin{aligned}\int_{C_3} f(z) dz &= \int_{C_{31}} f(z) dz + \int_{C_{32}} f(z) dz \\ &= \frac{5}{6} i.\end{aligned}$$

Suppose there is a number  $M$  so that  $|f(z)| \leq M$  for all  $z \in C$ . Then

$$\begin{aligned}\left| \int_C f(z) dz \right| &= \left| \int_{\alpha}^{\beta} f(\gamma(t)) \gamma'(t) dt \right| \\ &\leq \int_{\alpha}^{\beta} |f(\gamma(t)) \gamma'(t)| dt \\ &\leq M \int_{\alpha}^{\beta} |\gamma'(t)| dt = ML,\end{aligned}$$

where  $L = \int_{\alpha}^{\beta} |\gamma'(t)| dt$  is the length of  $C$ .

### Exercises

1. Evaluate the integral  $\int_C \bar{z} dz$ , where  $C$  is the parabola  $y = x^2$  from  $0$  to  $1 + i$ .
2. Evaluate  $\int_C \frac{1}{z} dz$ , where  $C$  is the circle of radius  $2$  centered at  $0$  oriented counterclockwise.
4. Evaluate  $\int_C f(z) dz$ , where  $C$  is the curve  $y = x^3$  from  $-1 - i$  to  $1 + i$ , and

$$f(z) = \begin{cases} 1 & \text{for } y < 0 \\ 4y & \text{for } y \geq 0 \end{cases}.$$

5. Let  $C$  be the part of the circle  $\gamma(t) = e^{it}$  in the first quadrant from  $a = 1$  to  $b = i$ . Find as small an upper bound as you can for  $\left| \int_C (z^2 - \bar{z}^4 + 5) dz \right|$ .

6. Evaluate  $\int_C f(z)dz$  where  $f(z) = z + 2\bar{z}$  and  $C$  is the path from  $z = 0$  to  $z = 1 + 2i$  consisting of the line segment from 0 to 1 together with the segment from 1 to  $1 + 2i$ .

**4.3 Antiderivatives.** Suppose  $D$  is a subset of the reals and  $\gamma : D \rightarrow \mathbf{C}$  is differentiable at  $t$ . Suppose further that  $g$  is differentiable at  $\gamma(t)$ . Then let's see about the derivative of the composition  $g(\gamma(t))$ . It is, in fact, exactly what one would guess. First,

$$g(\gamma(t)) = u(x(t), y(t)) + iv(x(t), y(t)),$$

where  $g(z) = u(x, y) + iv(x, y)$  and  $\gamma(t) = x(t) + iy(t)$ . Then,

$$\frac{d}{dt}g(\gamma(t)) = \frac{\partial u}{\partial x} \frac{dx}{dt} + \frac{\partial u}{\partial y} \frac{dy}{dt} + i \left( \frac{\partial v}{\partial x} \frac{dx}{dt} + \frac{\partial v}{\partial y} \frac{dy}{dt} \right).$$

The places at which the functions on the right-hand side of the equation are evaluated are obvious. Now, apply the Cauchy-Riemann equations:

$$\begin{aligned} \frac{d}{dt}g(\gamma(t)) &= \frac{\partial u}{\partial x} \frac{dx}{dt} - \frac{\partial v}{\partial x} \frac{dy}{dt} + i \left( \frac{\partial v}{\partial x} \frac{dx}{dt} + \frac{\partial u}{\partial x} \frac{dy}{dt} \right) \\ &= \left( \frac{\partial u}{\partial x} + i \frac{\partial v}{\partial x} \right) \left( \frac{dx}{dt} + i \frac{dy}{dt} \right) \\ &= g'(\gamma(t))\gamma'(t). \end{aligned}$$

The nicest result in the world!

Now, back to integrals. Let  $F : D \rightarrow \mathbf{C}$  and suppose  $F'(z) = f(z)$  in  $D$ . Suppose moreover that  $a$  and  $b$  are in  $D$  and that  $C \subset D$  is a contour from  $a$  to  $b$ . Then

$$\int_C f(z)dz = \int_a^\beta f(\gamma(t))\gamma'(t)dt,$$

where  $\gamma : [\alpha, \beta] \rightarrow C$  describes  $C$ . From our introductory discussion, we know that  $\frac{d}{dt}F(\gamma(t)) = F'(\gamma(t))\gamma'(t) = f(\gamma(t))\gamma'(t)$ . Hence,



$$\begin{aligned}
\int_C f(z) dz &= \int_{\alpha}^{\beta} f(\gamma(t)) \gamma'(t) dt \\
&= \int_{\alpha}^{\beta} \frac{d}{dt} F(\gamma(t)) dt = F(\gamma(\beta)) - F(\gamma(\alpha)) \\
&= F(b) - F(a).
\end{aligned}$$

This is very pleasing. Note that integral depends only on the points  $a$  and  $b$  and not at all on the path  $C$ . We say the integral is **path independent**. Observe that this is equivalent to saying that the integral of  $f$  around any closed path is 0. We have thus shown that if in  $D$  the integrand  $f$  is the derivative of a function  $F$ , then any integral  $\int_C f(z) dz$  for  $C \subset D$  is path independent.

### Example

Let  $C$  be the curve  $y = \frac{1}{x^2}$  from the point  $z = 1 + i$  to the point  $z = 3 + \frac{i}{9}$ . Let's find

$$\int_C z^2 dz.$$

This is easy—we know that  $F'(z) = z^2$ , where  $F(z) = \frac{1}{3}z^3$ . Thus,

$$\begin{aligned}
\int_C z^2 dz &= \frac{1}{3} \left[ (1 + i)^3 - \left( 3 + \frac{i}{9} \right)^3 \right] \\
&= -\frac{260}{27} - \frac{728}{2187}i
\end{aligned}$$

Now, instead of assuming  $f$  has an antiderivative, let us suppose that the integral of  $f$  between any two points in the domain is independent of path and that  $f$  is continuous. Assume also that every point in the domain  $D$  is an interior point of  $D$  and that  $D$  is connected. We shall see that in this case,  $f$  has an antiderivative. To do so, let  $z_0$  be any point in  $D$ , and define the function  $F$  by

$$F(z) = \int_{C_z} f(z) dz,$$

where  $C_z$  is any path in  $D$  from  $z_0$  to  $z$ . Here is important that the integral is path independent, otherwise  $F(z)$  would not be well-defined. Note also we need the assumption that  $D$  is connected in order to be sure there always is at least one such path.

Now, for the computation of the derivative of  $F$ :

$$F(z + \Delta z) - F(z) = \int_{L_{\Delta z}} f(s) ds,$$

where  $L_{\Delta z}$  is the line segment from  $z$  to  $z + \Delta z$ .

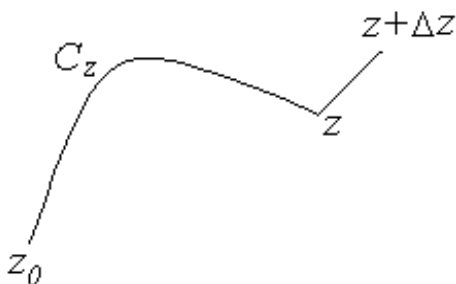

Next, observe that  $\int_{L_{\Delta z}} ds = \Delta z$ . Thus,  $f(z) = \frac{1}{\Delta z} \int_{L_{\Delta z}} f(z) ds$ , and we have

$$\frac{F(z + \Delta z) - F(z)}{\Delta z} - f(z) = \frac{1}{\Delta z} \int_{L_{\Delta z}} (f(s) - f(z)) ds.$$

Now then,

$$\left| \frac{1}{\Delta z} \int_{L_{\Delta z}} (f(s) - f(z)) ds \right| \leq \left| \frac{1}{\Delta z} \right| |\Delta z| \max\{|f(s) - f(z)| : s \in L_{\Delta z}\} \\ \leq \max\{|f(s) - f(z)| : s \in L_{\Delta z}\}.$$

We know  $f$  is continuous at  $z$ , and so  $\lim_{\Delta z \rightarrow 0} \max\{|f(s) - f(z)| : s \in L_{\Delta z}\} = 0$ . Hence,

$$\lim_{\Delta z \rightarrow 0} \frac{F(z + \Delta z) - F(z)}{\Delta z} - f(z) = \lim_{\Delta z \rightarrow 0} \left( \frac{1}{\Delta z} \int_{L_{\Delta z}} (f(s) - f(z)) ds \right) \\ = 0.$$

In other words,  $F'(z) = f(z)$ , and so, just as promised,  $f$  has an antiderivative! Let's summarize what we have shown in this section:

Suppose  $f : D \rightarrow \mathbf{C}$  is continuous, where  $D$  is connected and every point of  $D$  is an interior point. Then  $f$  has an antiderivative if and only if the integral between any two points of  $D$  is path independent.

### Exercises

7. Suppose  $C$  is any curve from  $0$  to  $\pi + 2i$ . Evaluate the integral

$$\int_C \cos\left(\frac{z}{2}\right) dz.$$

8. a) Let  $F(z) = \log z$ ,  $0 < \arg z < 2\pi$ . Show that the derivative  $F'(z) = \frac{1}{z}$ .

b) Let  $G(z) = \log z$ ,  $-\frac{\pi}{4} < \arg z < \frac{7\pi}{4}$ . Show that the derivative  $G'(z) = \frac{1}{z}$ .

c) Let  $C_1$  be a curve in the right-half plane  $D_1 = \{z : \operatorname{Re} z \geq 0\}$  from  $-i$  to  $i$  that does not pass through the origin. Find the integral

$$\int_{C_1} \frac{1}{z} dz.$$

d) Let  $C_2$  be a curve in the left-half plane  $D_2 = \{z : \operatorname{Re} z \leq 0\}$  from  $-i$  to  $i$  that does not pass through the origin. Find the integral.

$$\int_{C_2} \frac{1}{z} dz.$$

9. Let  $C$  be the circle of radius 1 centered at 0 with the *clockwise* orientation. Find

$$\int_C \frac{1}{z} dz.$$

10. a) Let  $H(z) = z^c$ ,  $-\pi < \arg z < \pi$ . Find the derivative  $H'(z)$ .

b) Let  $K(z) = z^c$ ,  $-\frac{\pi}{4} < \arg z < \frac{7\pi}{4}$ . What is the largest subset of the plane on which  $H(z) = K(z)$ ?

c) Let  $C$  be any path from  $-1$  to  $1$  that lies completely in the upper half-plane. (Upper

half-plane =  $\{z : \operatorname{Im} z \geq 0\}$ .) Find

$$\int_C F(z) dz,$$

where  $F(z) = z^i, -\pi < \arg z \leq \pi$ .

**11.** Suppose  $P$  is a polynomial and  $C$  is a closed curve. Explain how you know that  $\int_C P(z) dz = 0$ .

## Chapter Five

# Cauchy's Theorem

**5.1. Homotopy.** Suppose  $D$  is a connected subset of the plane such that every point of  $D$  is an interior point—we call such a set a **region**—and let  $C_1$  and  $C_2$  be oriented closed curves in  $D$ . We say  $C_1$  is **homotopic** to  $C_2$  in  $D$  if there is a continuous function  $H : S \rightarrow D$ , where  $S$  is the square  $S = \{(t, s) : 0 \leq s, t \leq 1\}$ , such that  $H(t, 0)$  describes  $C_1$  and  $H(t, 1)$  describes  $C_2$ , and for each fixed  $s$ , the function  $H(t, s)$  describes a closed curve  $C_s$  in  $D$ . The function  $H$  is called a **homotopy** between  $C_1$  and  $C_2$ . Note that if  $C_1$  is homotopic to  $C_2$  in  $D$ , then  $C_2$  is homotopic to  $C_1$  in  $D$ . Just observe that the function  $K(t, s) = H(t, 1 - s)$  is a homotopy.

It is convenient to consider a point to be a closed curve. The point  $c$  is described by a constant function  $\gamma(t) = c$ . We thus speak of a closed curve  $C$  being homotopic to a constant—we sometimes say  $C$  is **contractible** to a point.

Emotionally, the fact that two closed curves are homotopic in  $D$  means that one can be continuously deformed into the other in  $D$ .

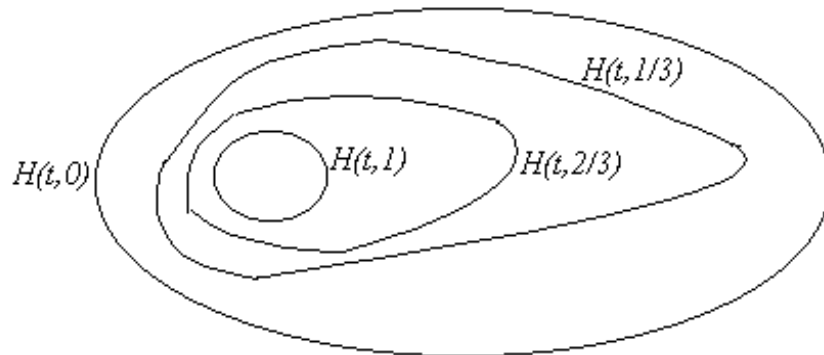

### Example

Let  $D$  be the annular region  $D = \{z : 1 < |z| < 5\}$ . Suppose  $C_1$  is the circle described by  $\gamma_1(t) = 2e^{i2\pi t}$ ,  $0 \leq t \leq 1$ ; and  $C_2$  is the circle described by  $\gamma_2(t) = 4e^{i2\pi t}$ ,  $0 \leq t \leq 1$ . Then  $H(t, s) = (2 + 2s)e^{i2\pi t}$  is a homotopy in  $D$  between  $C_1$  and  $C_2$ . Suppose  $C_3$  is the same circle as  $C_2$  but with the opposite orientation; that is, a description is given by  $\gamma_3(t) = 4e^{-i2\pi t}$ ,  $0 \leq t \leq 1$ . A homotopy between  $C_1$  and  $C_3$  is not too easy to construct—in fact, it is not possible! The moral: orientation counts. From now on, the term "closed curve" will mean an oriented closed curve.

### Another Example

Let  $D$  be the set obtained by removing the point  $z = 0$  from the plane. Take a look at the picture. Meditate on it and convince yourself that  $C$  and  $K$  are homotopic in  $D$ , but  $\Gamma$  and  $\Lambda$  are homotopic in  $D$ , while  $K$  and  $\Gamma$  are not homotopic in  $D$ .

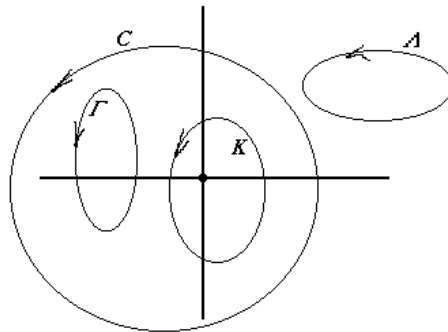

### Exercises

1. Suppose  $C_1$  is homotopic to  $C_2$  in  $D$ , and  $C_2$  is homotopic to  $C_3$  in  $D$ . Prove that  $C_1$  is homotopic to  $C_3$  in  $D$ .
2. Explain how you know that any two closed curves in the plane  $\mathbb{C}$  are homotopic in  $\mathbb{C}$ .
3. A region  $D$  is said to be **simply connected** if every closed curve in  $D$  is contractible to a point in  $D$ . Prove that any two closed curves in a simply connected region are homotopic in  $D$ .

**5.2 Cauchy's Theorem.** Suppose  $C_1$  and  $C_2$  are closed curves in a region  $D$  that are homotopic in  $D$ , and suppose  $f$  is a function analytic on  $D$ . Let  $H(t,s)$  be a homotopy between  $C_1$  and  $C_2$ . For each  $s$ , the function  $\gamma_s(t)$  describes a closed curve  $C_s$  in  $D$ . Let  $I(s)$  be given by

$$I(s) = \int_{C_s} f(z) dz.$$

Then,

$$I(s) = \int_0^1 f(H(t,s)) \frac{\partial H(t,s)}{\partial t} dt.$$

Now let's look at the derivative of  $I(s)$ . We assume everything is nice enough to allow us to differentiate under the integral:

$$\begin{aligned} I'(s) &= \frac{d}{ds} \left[ \int_0^1 f(H(t,s)) \frac{\partial H(t,s)}{\partial t} dt \right] \\ &= \int_0^1 \left[ f'(H(t,s)) \frac{\partial H(t,s)}{\partial s} \frac{\partial H(t,s)}{\partial t} + f(H(t,s)) \frac{\partial^2 H(t,s)}{\partial s \partial t} \right] dt \\ &= \int_0^1 \left[ f'(H(t,s)) \frac{\partial H(t,s)}{\partial s} \frac{\partial H(t,s)}{\partial t} + f(H(t,s)) \frac{\partial^2 H(t,s)}{\partial t \partial s} \right] dt \\ &= \int_0^1 \frac{\partial}{\partial t} \left[ f(H(t,s)) \frac{\partial H(t,s)}{\partial s} \right] dt \\ &= f(H(1,s)) \frac{\partial H(1,s)}{\partial s} - f(H(0,s)) \frac{\partial H(0,s)}{\partial s}. \end{aligned}$$

But we know each  $H(t,s)$  describes a closed curve, and so  $H(0,s) = H(1,s)$  for all  $s$ . Thus,

$$I'(s) = f(H(1,s)) \frac{\partial H(1,s)}{\partial s} - f(H(0,s)) \frac{\partial H(0,s)}{\partial s} = 0,$$

which means  $I(s)$  is constant! In particular,  $I(0) = I(1)$ , or

$$\int_{C_1} f(z) dz = \int_{C_2} f(z) dz.$$

This is a big deal. We have shown that if  $C_1$  and  $C_2$  are closed curves in a region  $D$  that are homotopic in  $D$ , and  $f$  is analytic on  $D$ , then  $\int_{C_1} f(z) dz = \int_{C_2} f(z) dz$ .

An easy corollary of this result is the celebrated **Cauchy's Theorem**, which says that if  $f$  is analytic on a simply connected region  $D$ , then for any closed curve  $C$  in  $D$ ,

$$\int_C f(z) dz = 0.$$

In court testimony, one is admonished to tell the truth, the whole truth, and nothing but the truth. Well, so far in this chapter, we have told the truth and nothing but the truth, but we have not quite told the whole truth. We assumed all sorts of continuous derivatives in the preceding discussion. These are not always necessary—specifically, the results can be proved true without all our smoothness assumptions—think about approximation.

### Example

Look at the picture below and convince your self that the path  $C$  is homotopic to the closed path consisting of the two curves  $C_1$  and  $C_2$  together with the line  $L$ . We traverse the line twice, once from  $C_1$  to  $C_2$  and once from  $C_2$  to  $C_1$ .

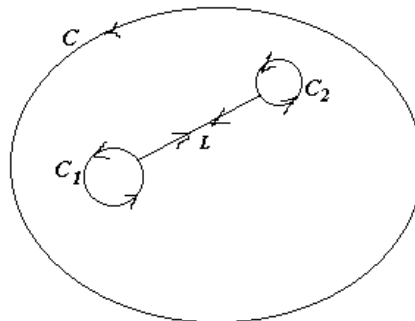

Observe then that an integral over this closed path is simply the sum of the integrals over  $C_1$  and  $C_2$ , since the two integrals along  $L$ , being in opposite directions, would sum to zero. Thus, if  $f$  is analytic in the region bounded by these curves (the region with two holes in it), then we know that

$$\int_C f(z) dz = \int_{C_1} f(z) dz + \int_{C_2} f(z) dz.$$

### Exercises

4. Prove Cauchy's Theorem.

5. Let  $S$  be the square with sides  $x = \pm 100$ , and  $y = \pm 100$  with the counterclockwise orientation. Find



$$\int_S \frac{1}{z} dz.$$

6. a) Find  $\int_C \frac{1}{z-1} dz$ , where  $C$  is any circle centered at  $z = 1$  with the usual counterclockwise orientation:  $\gamma(t) = 1 + Ae^{2\pi it}$ ,  $0 \leq t \leq 1$ .

b) Find  $\int_C \frac{1}{z+1} dz$ , where  $C$  is any circle centered at  $z = -1$  with the usual counterclockwise orientation.

c) Find  $\int_C \frac{1}{z^2-1} dz$ , where  $C$  is the ellipse  $4x^2 + y^2 = 100$  with the counterclockwise orientation. [Hint: partial fractions]

d) Find  $\int_C \frac{1}{z^2-1} dz$ , where  $C$  is the circle  $x^2 - 10x + y^2 = 0$  with the counterclockwise orientation.

8. Evaluate  $\int_C \text{Log}(z+3) dz$ , where  $C$  is the circle  $|z| = 2$  oriented counterclockwise.

9. Evaluate  $\int_C \frac{1}{z^n} dz$  where  $C$  is the circle described by  $\gamma(t) = e^{2\pi it}$ ,  $0 \leq t \leq 1$ , and  $n$  is an integer  $\neq 1$ .

10. a) Does the function  $f(z) = \frac{1}{z}$  have an antiderivative on the set of all  $z \neq 0$ ? Explain.

b) How about  $f(z) = \frac{1}{z^n}$ ,  $n$  an integer  $\neq 1$ ?

11. Find as large a set  $D$  as you can so that the function  $f(z) = e^{z^2}$  have an antiderivative on  $D$ .

12. Explain how you know that every function analytic in a simply connected (cf. Exercise 3) region  $D$  is the derivative of a function analytic in  $D$ .

## Chapter Six

### More Integration

**6.1. Cauchy's Integral Formula.** Suppose  $f$  is analytic in a region containing a simple closed contour  $C$  with the usual positive orientation and its inside, and suppose  $z_0$  is inside  $C$ . Then it turns out that

$$f(z_0) = \frac{1}{2\pi i} \int_C \frac{f(z)}{z - z_0} dz.$$

This is the famous **Cauchy Integral Formula**. Let's see why it's true.

Let  $\varepsilon > 0$  be any positive number. We know that  $f$  is continuous at  $z_0$  and so there is a number  $\delta$  such that  $|f(z) - f(z_0)| < \varepsilon$  whenever  $|z - z_0| < \delta$ . Now let  $\rho > 0$  be a number such that  $\rho < \delta$  and the circle  $C_0 = \{z : |z - z_0| = \rho\}$  is also inside  $C$ . Now, the function  $\frac{f(z)}{z - z_0}$  is analytic in the region between  $C$  and  $C_0$ ; thus

$$\int_C \frac{f(z)}{z - z_0} dz = \int_{C_0} \frac{f(z)}{z - z_0} dz.$$

We know that  $\int_{C_0} \frac{1}{z - z_0} dz = 2\pi i$ , so we can write

$$\begin{aligned} \int_{C_0} \frac{f(z)}{z - z_0} dz - 2\pi i f(z_0) &= \int_{C_0} \frac{f(z)}{z - z_0} dz - f(z_0) \int_{C_0} \frac{1}{z - z_0} dz \\ &= \int_{C_0} \frac{f(z) - f(z_0)}{z - z_0} dz. \end{aligned}$$

For  $z \in C_0$  we have

$$\begin{aligned} \left| \frac{f(z) - f(z_0)}{z - z_0} \right| &= \frac{|f(z) - f(z_0)|}{|z - z_0|} \\ &\leq \frac{\varepsilon}{\rho}. \end{aligned}$$

Thus,

$$\left| \int_{C_0} \frac{f(z)}{z-z_0} dz - 2\pi i f(z_0) \right| = \left| \int_{C_0} \frac{f(z) - f(z_0)}{z-z_0} dz \right|$$

$$\leq \frac{\varepsilon}{\rho} 2\pi \rho = 2\pi \varepsilon.$$

But  $\varepsilon$  is any positive number, and so

$$\left| \int_{C_0} \frac{f(z)}{z-z_0} dz - 2\pi i f(z_0) \right| = 0,$$

or,

$$f(z_0) = \frac{1}{2\pi i} \int_{C_0} \frac{f(z)}{z-z_0} dz = \frac{1}{2\pi i} \int_C \frac{f(z)}{z-z_0} dz,$$

which is exactly what we set out to show.

Meditate on this result. It says that if  $f$  is analytic on and inside a simple closed curve and we know the values  $f(z)$  for every  $z$  on the simple closed curve, then we know the value for the function at every point inside the curve—quite remarkable indeed.

### Example

Let  $C$  be the circle  $|z| = 4$  traversed once in the counterclockwise direction. Let's evaluate the integral

$$\int_C \frac{\cos z}{z^2 - 6z + 5} dz.$$

We simply write the integrand as

$$\frac{\cos z}{z^2 - 6z + 5} = \frac{\cos z}{(z-5)(z-1)} = \frac{f(z)}{z-1},$$

where

$$f(z) = \frac{\cos z}{z-5}.$$

Observe that  $f$  is analytic on and inside  $C$ , and so,

$$\begin{aligned} \int_C \frac{\cos z}{z^2 - 6z + 5} dz &= \int_C \frac{f(z)}{z - 1} dz = 2\pi i f(1) \\ &= 2\pi i \frac{\cos 1}{1 - 5} = -\frac{i\pi}{2} \cos 1 \end{aligned}$$

### Exercises

1. Suppose  $f$  and  $g$  are analytic on and inside the simple closed curve  $C$ , and suppose moreover that  $f(z) = g(z)$  for all  $z$  on  $C$ . Prove that  $f(z) = g(z)$  for all  $z$  inside  $C$ .

2. Let  $C$  be the ellipse  $9x^2 + 4y^2 = 36$  traversed once in the counterclockwise direction. Define the function  $g$  by

$$g(z) = \int_C \frac{s^2 + s + 1}{s - z} ds.$$

Find a)  $g(i)$

b)  $g(4i)$

3. Find

$$\int_C \frac{e^{2z}}{z^2 - 4} dz,$$

where  $C$  is the closed curve in the picture:

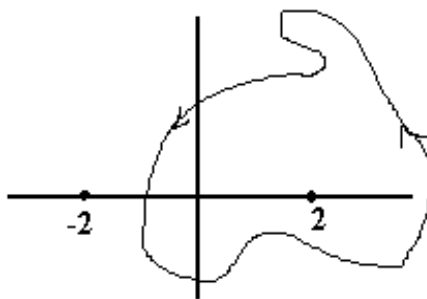

4. Find  $\int_{\Gamma} \frac{e^{2z}}{z^2 - 4} dz$ , where  $\Gamma$  is the contour in the picture:

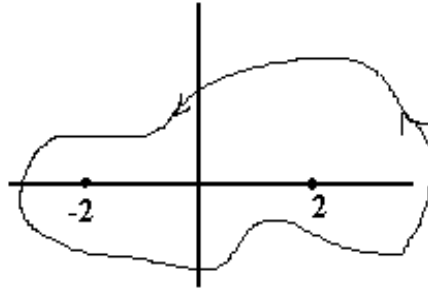

**6.2. Functions defined by integrals.** Suppose  $C$  is a curve (not necessarily a simple closed curve, just a curve) and suppose the function  $g$  is continuous on  $C$  (not necessarily analytic, just continuous). Let the function  $G$  be defined by

$$G(z) = \int_C \frac{g(s)}{s-z} ds$$

for all  $z \notin C$ . We shall show that  $G$  is analytic. Here we go.

Consider,

$$\begin{aligned} \frac{G(z + \Delta z) - G(z)}{\Delta z} &= \frac{1}{\Delta z} \int_C \left[ \frac{1}{s-z-\Delta z} - \frac{1}{s-z} \right] g(s) ds \\ &= \int_C \frac{g(s)}{(s-z-\Delta z)(s-z)} ds. \end{aligned}$$

Next,

$$\begin{aligned} \frac{G(z + \Delta z) - G(z)}{\Delta z} - \int_C \frac{g(s)}{(s-z)^2} ds &= \int_C \left[ \frac{1}{(s-z-\Delta z)(s-z)} - \frac{1}{(s-z)^2} \right] g(s) ds \\ &= \int_C \left[ \frac{(s-z) - (s-z-\Delta z)}{(s-z-\Delta z)(s-z)^2} \right] g(s) ds \\ &= \Delta z \int_C \frac{g(s)}{(s-z-\Delta z)(s-z)^2} ds. \end{aligned}$$

Now we want to show that

$$\lim_{\Delta z \rightarrow 0} \left[ \Delta z \int_C \frac{g(s)}{(s-z-\Delta z)(s-z)^2} ds \right] = 0.$$

To that end, let  $M = \max\{|g(s)| : s \in C\}$ , and let  $d$  be the shortest distance from  $z$  to  $C$ . Thus, for  $s \in C$ , we have  $|s-z| \geq d > 0$  and also

$$|s-z-\Delta z| \geq |s-z| - |\Delta z| \geq d - |\Delta z|.$$

Putting this all together, we can estimate the integrand above:

$$\left| \frac{g(s)}{(s-z-\Delta z)(s-z)^2} \right| \leq \frac{M}{(d-|\Delta z|)d^2}$$

for all  $s \in C$ . Finally,

$$\left| \Delta z \int_C \frac{g(s)}{(s-z-\Delta z)(s-z)^2} ds \right| \leq |\Delta z| \frac{M}{(d-|\Delta z|)d^2} \text{length}(C),$$

and it is clear that

$$\lim_{\Delta z \rightarrow 0} \left[ \Delta z \int_C \frac{g(s)}{(s-z-\Delta z)(s-z)^2} ds \right] = 0,$$

just as we set out to show. Hence  $G$  has a derivative at  $z$ , and

$$G'(z) = \int_C \frac{g(s)}{(s-z)^2} ds.$$

Truly a miracle!

Next we see that  $G'$  has a derivative and it is just what you think it should be. Consider

$$\begin{aligned}
\frac{G'(z + \Delta z) - G'(z)}{\Delta z} &= \frac{1}{\Delta z} \int_C \left[ \frac{1}{(s - z - \Delta z)^2} - \frac{1}{(s - z)^2} \right] g(s) ds \\
&= \frac{1}{\Delta z} \int_C \left[ \frac{(s - z)^2 - (s - z - \Delta z)^2}{(s - z - \Delta z)^2 (s - z)^2} \right] g(s) ds \\
&= \frac{1}{\Delta z} \int_C \left[ \frac{2(s - z)\Delta z - (\Delta z)^2}{(s - z - \Delta z)^2 (s - z)^2} \right] g(s) ds \\
&= \int_C \left[ \frac{2(s - z) - \Delta z}{(s - z - \Delta z)^2 (s - z)^2} \right] g(s) ds
\end{aligned}$$

Next,

$$\begin{aligned}
&\frac{G'(z + \Delta z) - G'(z)}{\Delta z} - 2 \int_C \frac{g(s)}{(s - z)^3} ds \\
&= \int_C \left[ \frac{2(s - z) - \Delta z}{(s - z - \Delta z)^2 (s - z)^2} - \frac{2}{(s - z)^3} \right] g(s) ds \\
&= \int_C \left[ \frac{2(s - z)^2 - \Delta z(s - z) - 2(s - z - \Delta z)^2}{(s - z - \Delta z)^2 (s - z)^3} \right] g(s) ds \\
&= \int_C \left[ \frac{2(s - z)^2 - \Delta z(s - z) - 2(s - z)^2 + 4\Delta z(s - z) - 2(\Delta z)^2}{(s - z - \Delta z)^2 (s - z)^3} \right] g(s) ds \\
&= \int_C \left[ \frac{3\Delta z(s - z) - 2(\Delta z)^2}{(s - z - \Delta z)^2 (s - z)^3} \right] g(s) ds
\end{aligned}$$

Hence,

$$\begin{aligned}
\left| \frac{G'(z + \Delta z) - G'(z)}{\Delta z} - 2 \int_C \frac{g(s)}{(s - z)^3} ds \right| &= \left| \int_C \left[ \frac{3\Delta z(s - z) - 2(\Delta z)^2}{(s - z - \Delta z)^2 (s - z)^3} \right] g(s) ds \right| \\
&\leq |\Delta z| \frac{(|3m| + 2|\Delta z|)M}{(d - \Delta z)^2 d^3},
\end{aligned}$$

where  $m = \max\{|s - z| : s \in C\}$ . It should be clear then that

$$\lim_{\Delta z \rightarrow 0} \left| \frac{G'(z + \Delta z) - G'(z)}{\Delta z} - 2 \int_C \frac{g(s)}{(s - z)^3} ds \right| = 0,$$

or in other words,

$$G''(z) = 2 \int_C \frac{g(s)}{(s-z)^3} ds.$$

Suppose  $f$  is analytic in a region  $D$  and suppose  $C$  is a positively oriented simple closed curve in  $D$ . Suppose also the inside of  $C$  is in  $D$ . Then from the Cauchy Integral formula, we know that

$$2\pi i f(z) = \int_C \frac{f(s)}{s-z} ds$$

and so with  $g = f$  in the formulas just derived, we have

$$f'(z) = \frac{1}{2\pi i} \int_C \frac{f(s)}{(s-z)^2} ds, \text{ and } f''(z) = \frac{2}{2\pi i} \int_C \frac{f(s)}{(s-z)^3} ds$$

for all  $z$  inside the closed curve  $C$ . Meditate on these results. They say that the derivative of an analytic function is also analytic. Now suppose  $f$  is continuous on a domain  $D$  in which every point of  $D$  is an interior point and suppose that  $\int_C f(z) dz = 0$  for every closed curve in  $D$ . Then we know that  $f$  has an antiderivative in  $D$ —in other words  $f$  is the derivative of an analytic function. We now know this means that  $f$  is itself analytic. We thus have the celebrated **Morera's Theorem**:

If  $f: D \rightarrow \mathbf{C}$  is continuous and such that  $\int_C f(z) dz = 0$  for every closed curve in  $D$ , then  $f$  is analytic in  $D$ .

### Example

Let's evaluate the integral

$$\int_C \frac{e^z}{z^3} dz,$$

where  $C$  is any positively oriented closed curve around the origin. We simply use the equation

$$f''(z) = \frac{2}{2\pi i} \int_C \frac{f(s)}{(s-z)^3} ds$$



with  $z = 0$  and  $f(s) = e^s$ . Thus,

$$\pi i e^0 = \pi i = \int_C \frac{e^z}{z^3} dz.$$

## Exercises

5. Evaluate

$$\int_C \frac{\sin z}{z^2} dz$$

where  $C$  is a positively oriented closed curve around the origin.

6. Let  $C$  be the circle  $|z - i| = 2$  with the positive orientation. Evaluate

a)  $\int_C \frac{1}{z^2+4} dz$

b)  $\int_C \frac{1}{(z^2+4)^2} dz$

7. Suppose  $f$  is analytic inside and on the simple closed curve  $C$ . Show that

$$\int_C \frac{f'(z)}{z-w} dz = \int_C \frac{f(z)}{(z-w)^2} dz$$

for every  $w \notin C$ .

8. a) Let  $\alpha$  be a real constant, and let  $C$  be the circle  $\gamma(t) = e^{it}$ ,  $-\pi \leq t \leq \pi$ . Evaluate

$$\int_C \frac{e^{\alpha z}}{z} dz.$$

b) Use your answer in part a) to show that

$$\int_0^\pi e^{\alpha \cos t} \cos(\alpha \sin t) dt = \pi.$$

**6.3. Liouville's Theorem.** Suppose  $f$  is entire and bounded; that is,  $f$  is analytic in the entire plane and there is a constant  $M$  such that  $|f(z)| \leq M$  for all  $z$ . Then it must be true that  $f'(z) = 0$  identically. To see this, suppose that  $f'(w) \neq 0$  for some  $w$ . Choose  $R$  large enough to insure that  $\frac{M}{R} < |f'(w)|$ . Now let  $C$  be a circle centered at 0 and with radius

$\rho > \max\{R, |w|\}$ . Then we have :

$$\begin{aligned} \frac{M}{\rho} < |f'(w)| &\leq \left| \frac{1}{2\pi i} \int_C \frac{f(s)}{(s-w)^2} dz \right| \\ &\leq \frac{1}{2\pi} \frac{M}{\rho^2} 2\pi\rho = \frac{M}{\rho}, \end{aligned}$$

a contradiction. It must therefore be true that there is no  $w$  for which  $f'(w) \neq 0$ ; or, in other words,  $f'(z) = 0$  for all  $z$ . This, of course, means that  $f$  is a constant function. What we have shown has a name, **Liouville's Theorem**:

The only bounded entire functions are the constant functions.

Let's put this theorem to some good use. Let  $p(z) = a_n z^n + a_{n-1} z^{n-1} + \dots + a_1 z + a_0$  be a polynomial. Then

$$p(z) = \left( a_n + \frac{a_{n-1}}{z} + \frac{a_{n-2}}{z^2} + \dots + \frac{a_0}{z^n} \right) z^n.$$

Now choose  $R$  large enough to insure that for each  $j = 1, 2, \dots, n$ , we have  $\left| \frac{a_{n-j}}{z^j} \right| < \frac{|a_n|}{2n}$  whenever  $|z| > R$ . (We are assuming that  $a_n \neq 0$ .) Hence, for  $|z| > R$ , we know that

$$\begin{aligned} |p(z)| &\geq \left| |a_n| - \left| \frac{a_{n-1}}{z} + \frac{a_{n-2}}{z^2} + \dots + \frac{a_0}{z^n} \right| \right| |z|^n \\ &\geq \left| |a_n| - \left| \frac{a_{n-1}}{z} \right| - \left| \frac{a_{n-2}}{z^2} \right| - \dots - \left| \frac{a_0}{z^n} \right| \right| |z|^n \\ &> \left| |a_n| - \frac{|a_n|}{2n} - \frac{|a_n|}{2n} - \dots - \frac{|a_n|}{2n} \right| |z|^n \\ &> \frac{|a_n|}{2} |z|^n. \end{aligned}$$

Hence, for  $|z| > R$ ,

$$\frac{1}{p(z)} < \frac{2}{|a_n| |z|^n} \leq \frac{2}{|a_n| R^n}.$$

Now suppose  $p(z) \neq 0$  for all  $z$ . Then  $\frac{1}{p(z)}$  is also bounded on the disk  $|z| \leq R$ . Thus,  $\frac{1}{p(z)}$  is a bounded entire function, and hence, by Liouville's Theorem, constant! Hence the polynomial is constant if it has no zeros. In other words, if  $p(z)$  is of degree at least one, there must be at least one  $z_0$  for which  $p(z_0) = 0$ . This is, of course, the celebrated

## Fundamental Theorem of Algebra.

### Exercises

9. Suppose  $f$  is an entire function, and suppose there is an  $M$  such that  $\operatorname{Re}f(z) \leq M$  for all  $z$ . Prove that  $f$  is a constant function.

10. Suppose  $w$  is a solution of  $5z^4 + z^3 + z^2 - 7z + 14 = 0$ . Prove that  $|w| \leq 3$ .

11. Prove that if  $p$  is a polynomial of degree  $n$ , and if  $p(a) = 0$ , then  $p(z) = (z - a)q(z)$ , where  $q$  is a polynomial of degree  $n - 1$ .

12. Prove that if  $p$  is a polynomial of degree  $n \geq 1$ , then

$$p(z) = c(z - z_1)^{k_1}(z - z_2)^{k_2} \dots (z - z_j)^{k_j},$$

where  $k_1, k_2, \dots, k_j$  are positive integers such that  $n = k_1 + k_2 + \dots + k_j$ .

13. Suppose  $p$  is a polynomial with real coefficients. Prove that  $p$  can be expressed as a product of linear and quadratic factors, each with real coefficients.

**6.4. Maximum moduli.** Suppose  $f$  is analytic on a closed domain  $D$ . Then, being continuous,  $|f(z)|$  must attain its maximum value somewhere in this domain. Suppose this happens at an interior point. That is, suppose  $|f(z)| \leq M$  for all  $z \in D$  and suppose that  $|f(z_0)| = M$  for some  $z_0$  in the interior of  $D$ . Now  $z_0$  is an interior point of  $D$ , so there is a number  $R$  such that the disk  $\Lambda$  centered at  $z_0$  having radius  $R$  is included in  $D$ . Let  $C$  be a positively oriented circle of radius  $\rho \leq R$  centered at  $z_0$ . From Cauchy's formula, we know

$$f(z_0) = \frac{1}{2\pi i} \int_C \frac{f(s)}{s - z_0} ds.$$

Hence,

$$f(z_0) = \frac{1}{2\pi} \int_0^{2\pi} f(z_0 + \rho e^{it}) dt,$$

and so,

$$M = |f(z_0)| \leq \frac{1}{2\pi} \int_0^{2\pi} |f(z_0 + \rho e^{it})| dt \leq M.$$

since  $|f(z_0 + \rho e^{it})| \leq M$ . This means

$$M = \frac{1}{2\pi} \int_0^{2\pi} |f(z_0 + \rho e^{it})| dt.$$

Thus,

$$M - \frac{1}{2\pi} \int_0^{2\pi} |f(z_0 + \rho e^{it})| dt = \frac{1}{2\pi} \int_0^{2\pi} [M - |f(z_0 + \rho e^{it})|] dt = 0.$$

This integrand is continuous and non-negative, and so must be zero. In other words,  $|f(z)| = M$  for all  $z \in C$ . There was nothing special about  $C$  except its radius  $\rho \leq R$ , and so we have shown that  $f$  must be constant on the disk  $\Lambda$ .

I hope it is easy to see that if  $D$  is a region (=connected and open), then the only way in which the modulus  $|f(z)|$  of the analytic function  $f$  can attain a maximum on  $D$  is for  $f$  to be constant.

### Exercises

**14.** Suppose  $f$  is analytic and not constant on a region  $D$  and suppose  $f(z) \neq 0$  for all  $z \in D$ . Explain why  $|f(z)|$  does not have a minimum in  $D$ .

**15.** Suppose  $f(z) = u(x,y) + iv(x,y)$  is analytic on a region  $D$ . Prove that if  $u(x,y)$  attains a maximum value in  $D$ , then  $u$  must be constant.

## Chapter Seven

# Harmonic Functions

**7.1. The Laplace equation.** The Fourier law of heat conduction says that the rate at which heat passes across a surface  $S$  is proportional to the flux, or surface integral, of the temperature gradient on the surface:

$$k \iint_S \nabla T \cdot dA.$$

Here  $k$  is the constant of proportionality, generally called the *thermal conductivity* of the substance (We assume uniform stuff. ). We further assume no heat sources or sinks, and we assume steady-state conditions—the temperature does not depend on time. Now if we take  $S$  to be an arbitrary closed surface, then this rate of flow must be 0:

$$k \iint_S \nabla T \cdot dA = 0.$$

Otherwise there would be more heat entering the region  $B$  bounded by  $S$  than is coming out, or vice-versa. Now, apply the celebrated Divergence Theorem to conclude that

$$\iiint_B (\nabla \cdot \nabla T) dV = 0,$$

where  $B$  is the region bounded by the closed surface  $S$ . But since the region  $B$  is completely arbitrary, this means that

$$\nabla \cdot \nabla T = \frac{\partial^2 T}{\partial x^2} + \frac{\partial^2 T}{\partial y^2} + \frac{\partial^2 T}{\partial z^2} = 0.$$

This is the world-famous **Laplace Equation**.

Now consider a slab of heat conducting material,

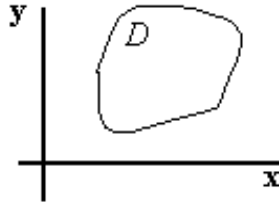

in which we assume there is no heat flow in the  $z$ -direction. Equivalently, we could assume we are looking at the cross-section of a long rod in which there is no longitudinal heat flow. In other words, we are looking at a two-dimensional problem—the temperature depends only on  $x$  and  $y$ , and satisfies the two-dimensional version of the Laplace equation:

$$\frac{\partial^2 T}{\partial x^2} + \frac{\partial^2 T}{\partial y^2} = 0.$$

Suppose now, for instance, the temperature is specified on the boundary of our region  $D$ , and we wish to find the temperature  $T(x,y)$  in region. We are simply looking for a solution of the Laplace equation that satisfies the specified boundary condition.

Let's look at another physical problem which leads to Laplace's equation. Gauss's Law of electrostatics tells us that the integral over a closed surface  $S$  of the electric field  $\mathbf{E}$  is proportional to the charge included in the region  $B$  enclosed by  $S$ . Thus in the absence of any charge, we have

$$\iint_S \mathbf{E} \cdot d\mathbf{A} = 0.$$

But in this case, we know the field  $\mathbf{E}$  is conservative; let  $\phi$  be the potential function—that is,

$$\mathbf{E} = \nabla\phi.$$

Thus,

$$\iint_S \mathbf{E} \cdot d\mathbf{A} = \iint_S \nabla\phi \cdot d\mathbf{A}.$$

Again, we call on the Divergence Theorem to conclude that  $\phi$  must satisfy the Laplace equation. Mathematically, we cannot tell the problem of finding the electric potential in a

region  $D$ , given the potential on the boundary of  $D$ , from the previous problem of finding the temperature in the region, given the temperature on the boundary. These are but two of the many physical problems that lead to the Laplace equation—You probably already know of some others. Let  $D$  be a domain and let  $\sigma$  be a given function continuous on the boundary of  $D$ . The problem of finding a function  $\varphi$  harmonic on the interior of  $D$  and which agrees with  $\sigma$  on the boundary of  $D$  is called the **Dirichlet problem**.

**7.2. Harmonic functions.** If  $D$  is a region in the plane, a real-valued function  $u(x,y)$  having continuous second partial derivatives is said to be **harmonic** on  $D$  if it satisfies Laplace's equation on  $D$  :

$$\frac{\partial^2 u}{\partial x^2} + \frac{\partial^2 u}{\partial y^2} = 0.$$

There is an intimate relationship between harmonic functions and analytic functions. Suppose  $f$  is analytic on  $D$ , and let  $f(z) = u(x,y) + iv(x,y)$ . Now, from the Cauchy-Riemann equations, we know

$$\begin{aligned} \frac{\partial u}{\partial x} &= \frac{\partial v}{\partial y}, \text{ and} \\ \frac{\partial u}{\partial y} &= -\frac{\partial v}{\partial x}. \end{aligned}$$

If we differentiate the first of these with respect to  $x$  and the second with respect to  $y$ , and then add the two results, we have

$$\frac{\partial^2 u}{\partial x^2} + \frac{\partial^2 u}{\partial y^2} = \frac{\partial^2 v}{\partial x \partial y} - \frac{\partial^2 v}{\partial y \partial x} = 0.$$

Thus the real part of any analytic function is harmonic! Next, if we differentiate the first of the Cauchy-Riemann equations with respect to  $y$  and the second with respect to  $x$ , and then subtract the second from the first, we have

$$\frac{\partial^2 v}{\partial x^2} + \frac{\partial^2 v}{\partial y^2} = 0,$$

and we see that the imaginary part of an analytic function is also harmonic.

There is even more excitement. Suppose we are given a function  $\varphi$  harmonic in a *simply connected* region  $D$ . Then there is a function  $f$  analytic on  $D$  which is such that  $\text{Re} f = \varphi$ . Let's see why this is so. First, define  $g$  by

$$g(z) = \frac{\partial \varphi}{\partial x} - i \frac{\partial \varphi}{\partial y}.$$

We'll show that  $g$  is analytic by verifying that the real and imaginary parts satisfy the Cauchy-Riemann equations:

$$\frac{\partial}{\partial x} \left( \frac{\partial \varphi}{\partial x} \right) = \frac{\partial^2 \varphi}{\partial x^2} = -\frac{\partial^2 \varphi}{\partial y^2} = \frac{\partial}{\partial y} \left( -\frac{\partial \varphi}{\partial y} \right),$$

since  $\varphi$  is harmonic. Next,

$$\frac{\partial}{\partial y} \left( \frac{\partial \varphi}{\partial x} \right) = \frac{\partial^2 \varphi}{\partial y \partial x} = \frac{\partial^2 \varphi}{\partial x \partial y} = -\frac{\partial}{\partial x} \left( -\frac{\partial \varphi}{\partial y} \right).$$

Since  $g$  is analytic on the simply connected region  $D$ , we know that the integral of  $g$  around any closed curve is zero, and so it has an antiderivative  $G(z) = u + iv$ . This antiderivative is, of course, analytic on  $D$ , and we know that

$$G'(z) = \frac{\partial u}{\partial x} - i \frac{\partial u}{\partial y} = \frac{\partial \varphi}{\partial x} - i \frac{\partial \varphi}{\partial y}.$$

Thus,  $u(x, y) = \varphi(x, y) + h(y)$ . From this,

$$\frac{\partial u}{\partial y} = \frac{\partial \varphi}{\partial y} + h'(y),$$

and so  $h'(y) = 0$ , or  $h = \text{constant}$ , from which it follows that  $u(x, y) = \varphi(x, y) + c$ . In other words,  $\text{Re } G = u$ , as we promised to show.

### Example

The function  $\varphi(x, y) = x^3 - 3xy^2$  is harmonic everywhere. We shall find an analytic function  $G$  so that  $\text{Re } G = \varphi$ . We know that  $G(z) = (x^3 - 3xy^2) + iv$ , and so from the Cauchy-Riemann equations:

$$\frac{\partial v}{\partial x} = -\frac{\partial u}{\partial y} = 6xy$$



Hence,

$$v(x,y) = 3x^2y + k(y).$$

To find  $k(y)$  differentiate with respect to  $y$  :

$$\frac{\partial v}{\partial y} = 3x^2 + k'(y) = \frac{\partial u}{\partial x} = 3x^2 - 3y^2,$$

and so,

$$\begin{aligned} k'(y) &= -3y^2, \text{ or} \\ k(y) &= -y^3 + \text{any constant.} \end{aligned}$$

If we choose the constant to be zero, this gives us

$$v = 3x^2y + k(y) = 3x^2y - y^3,$$

and finally,

$$G(z) = u + iv = (x^3 - 3xy^2) + i(3x^2y - y^3).$$

### Exercises

1. Suppose  $\varphi$  is harmonic on a simply connected region  $D$ . Prove that if  $\varphi$  assumes its maximum or its minimum value at some point in  $D$ , then  $\varphi$  is constant in  $D$ .
2. Suppose  $\varphi$  and  $\sigma$  are harmonic in a simply connected region  $D$  bounded by the curve  $C$ . Suppose moreover that  $\varphi(x,y) = \sigma(x,y)$  for all  $(x,y) \in C$ . Explain how you know that  $\varphi = \sigma$  everywhere in  $D$ .
3. Find an entire function  $f$  such that  $\operatorname{Re} f = x^2 - 3x - y^2$ , or explain why there is no such function  $f$ .
4. Find an entire function  $f$  such that  $\operatorname{Re} f = x^2 + 3x - y^2$ , or explain why there is no such function  $f$ .

**7.3. Poisson's integral formula.** Let  $\Lambda$  be the disk bounded by the circle  $C_\rho = \{z : |z| = \rho\}$ . Suppose  $\varphi$  is harmonic on  $\Lambda$  and let  $f$  be a function analytic on  $\Lambda$  and such that  $\operatorname{Re} f = \varphi$ . Now then, for fixed  $z$  with  $|z| < \rho$ , the function

$$g(s) = \frac{f(s)\bar{z}}{\rho^2 - s\bar{z}}$$

is analytic on  $\Lambda$ . Thus from Cauchy's Theorem

$$\int_{C_\rho} g(s) ds = \int_{C_\rho} \frac{f(s)\bar{z}}{\rho^2 - s\bar{z}} ds = 0.$$

We know also that

$$f(z) = \frac{1}{2\pi i} \int_{C_\rho} \frac{f(s)}{s-z} ds.$$

Adding these two equations gives us

$$\begin{aligned} f(z) &= \frac{1}{2\pi i} \int_{C_\rho} \left( \frac{1}{s-z} + \frac{\bar{z}}{\rho^2 - s\bar{z}} \right) f(s) ds \\ &= \frac{1}{2\pi i} \int_{C_\rho} \frac{\rho^2 - |z|^2}{(s-z)(\rho^2 - s\bar{z})} f(s) ds. \end{aligned}$$

Next, let  $\gamma(t) = \rho e^{it}$ , and our integral becomes

$$\begin{aligned} f(z) &= \frac{1}{2\pi i} \int_0^{2\pi} \frac{\rho^2 - |z|^2}{(\rho e^{it} - z)(\rho^2 - \rho e^{it}\bar{z})} f(\rho e^{it}) i \rho e^{it} dt \\ &= \frac{\rho^2 - |z|^2}{2\pi} \int_0^{2\pi} \frac{f(\rho e^{it})}{(\rho e^{it} - z)(\rho e^{-it} - \bar{z})} dt \\ &= \frac{\rho^2 - |z|^2}{2\pi} \int_0^{2\pi} \frac{f(\rho e^{it})}{|\rho e^{it} - z|^2} dt \end{aligned}$$

Now,

$$\varphi(x,y) = \operatorname{Re} f = \frac{\rho^2 - |z|^2}{2\pi} \int_0^{2\pi} \frac{\varphi(\rho e^{it})}{|\rho e^{it} - z|^2} dt.$$

Next, use polar coordinates:  $z = re^{i\theta}$  :

$$\varphi(r, \theta) = \frac{\rho^2 - r^2}{2\pi} \int_0^{2\pi} \frac{\varphi(\rho e^{it})}{|\rho e^{it} - re^{i\theta}|^2} dt.$$

Now,

$$\begin{aligned} |\rho e^{it} - re^{i\theta}|^2 &= (\rho e^{it} - re^{i\theta})(\rho e^{-it} - re^{-i\theta}) = \rho^2 + r^2 - r\rho(e^{i(t-\theta)} + e^{-i(t-\theta)}) \\ &= \rho^2 + r^2 - 2r\rho \cos(t - \theta). \end{aligned}$$

Substituting this in the integral, we have **Poisson's integral formula**:

$$\varphi(r, \theta) = \frac{\rho^2 - r^2}{2\pi} \int_0^{2\pi} \frac{\varphi(\rho e^{it})}{\rho^2 + r^2 - 2r\rho \cos(t - \theta)} dt$$

This famous formula essentially solves the Dirichlet problem for a disk.

### Exercises

5. Evaluate  $\int_0^{2\pi} \frac{1}{\rho^2 + r^2 - 2r\rho \cos(t - \theta)} dt$ . [Hint: This is easy.]

6. Suppose  $\varphi$  is harmonic in a region  $D$ . If  $(x_0, y_0) \in D$  and if  $C \subset D$  is a circle centered at  $(x_0, y_0)$ , the inside of which is also in  $D$ , then  $\varphi(x_0, y_0)$  is the average value of  $\varphi$  on the circle  $C$ .

7. Suppose  $\varphi$  is harmonic on the disk  $\Lambda = \{z : |z| \leq \rho\}$ . Prove that

$$\varphi(0,0) = \frac{1}{\pi\rho^2} \iint_{\Lambda} \varphi dA.$$

## Chapter Eight

### Series

**8.1. Sequences.** The basic definitions for complex sequences and series are essentially the same as for the real case. A **sequence** of complex numbers is a function  $g : Z_+ \rightarrow \mathbf{C}$  from the positive integers into the complex numbers. It is traditional to use subscripts to indicate the values of the function. Thus we write  $g(n) \equiv z_n$  and an explicit name for the sequence is seldom used; we write simply  $(z_n)$  to stand for the sequence  $g$  which is such that  $g(n) = z_n$ . For example,  $(\frac{i}{n})$  is the sequence  $g$  for which  $g(n) = \frac{i}{n}$ .

The number  $L$  is a **limit** of the sequence  $(z_n)$  if given an  $\varepsilon > 0$ , there is an integer  $N_\varepsilon$  such that  $|z_n - L| < \varepsilon$  for all  $n \geq N_\varepsilon$ . If  $L$  is a limit of  $(z_n)$ , we sometimes say that  $(z_n)$  **converges** to  $L$ . We frequently write  $\lim(z_n) = L$ . It is relatively easy to see that if the complex sequence  $(z_n) = (u_n + iv_n)$  converges to  $L$ , then the two real sequences  $(u_n)$  and  $(v_n)$  each have a limit:  $(u_n)$  converges to  $\operatorname{Re}L$  and  $(v_n)$  converges to  $\operatorname{Im}L$ . Conversely, if the two real sequences  $(u_n)$  and  $(v_n)$  each have a limit, then so also does the complex sequence  $(u_n + iv_n)$ . All the usual nice properties of limits of sequences are thus true:

$$\begin{aligned}\lim(z_n \pm w_n) &= \lim(z_n) \pm \lim(w_n); \\ \lim(z_n w_n) &= \lim(z_n) \lim(w_n); \text{ and} \\ \lim\left(\frac{z_n}{w_n}\right) &= \frac{\lim(z_n)}{\lim(w_n)}.\end{aligned}$$

provided that  $\lim(z_n)$  and  $\lim(w_n)$  exist. (And in the last equation, we must, of course, insist that  $\lim(w_n) \neq 0$ .)

A necessary and sufficient condition for the convergence of a sequence  $(a_n)$  is the celebrated **Cauchy criterion**: given  $\varepsilon > 0$ , there is an integer  $N_\varepsilon$  so that  $|a_n - a_m| < \varepsilon$  whenever  $n, m > N_\varepsilon$ .

A sequence  $(f_n)$  of functions on a domain  $D$  is the obvious thing: a function from the positive integers into the set of complex functions on  $D$ . Thus, for each  $z \in D$ , we have an ordinary sequence  $(f_n(z))$ . If each of the sequences  $(f_n(z))$  converges, then we say the sequence of functions  $(f_n)$  converges to the function  $f$  defined by  $f(z) = \lim(f_n(z))$ . This pretty obvious stuff. The sequence  $(f_n)$  is said to converge to  $f$  **uniformly** on a set  $S$  if given an  $\varepsilon > 0$ , there is an integer  $N_\varepsilon$  so that  $|f_n(z) - f(z)| < \varepsilon$  for all  $n \geq N_\varepsilon$  and all  $z \in S$ .

Note that it is possible for a sequence of continuous functions to have a limit function that is *not* continuous. This cannot happen if the convergence is uniform. To see this, suppose the sequence  $(f_n)$  of continuous functions converges uniformly to  $f$  on a domain  $D$ , let  $z_0 \in D$ , and let  $\varepsilon > 0$ . We need to show there is a  $\delta$  so that  $|f(z_0) - f(z)| < \varepsilon$  whenever

$|z_0 - z| < \delta$ . Let's do it. First, choose  $N$  so that  $|f_N(z) - f(z)| < \frac{\varepsilon}{3}$ . We can do this because of the uniform convergence of the sequence  $(f_n)$ . Next, choose  $\delta$  so that  $|f_N(z_0) - f_N(z)| < \frac{\varepsilon}{3}$  whenever  $|z_0 - z| < \delta$ . This is possible because  $f_N$  is continuous. Now then, when  $|z_0 - z| < \delta$ , we have

$$\begin{aligned} |f(z_0) - f(z)| &= |f(z_0) - f_N(z_0) + f_N(z_0) - f_N(z) + f_N(z) - f(z)| \\ &\leq |f(z_0) - f_N(z_0)| + |f_N(z_0) - f_N(z)| + |f_N(z) - f(z)| \\ &< \frac{\varepsilon}{3} + \frac{\varepsilon}{3} + \frac{\varepsilon}{3} = \varepsilon, \end{aligned}$$

and we have done it!

Now suppose we have a sequence  $(f_n)$  of continuous functions which converges uniformly on a contour  $C$  to the function  $f$ . Then the sequence  $\left( \int_C f_n(z) dz \right)$  converges to  $\int_C f(z) dz$ . This is easy to see. Let  $\varepsilon > 0$ . Now let  $N$  be so that  $|f_n(z) - f(z)| < \frac{\varepsilon}{A}$  for  $n > N$ , where  $A$  is the length of  $C$ . Then,

$$\begin{aligned} \left| \int_C f_n(z) dz - \int_C f(z) dz \right| &= \left| \int_C (f_n(z) - f(z)) dz \right| \\ &< \frac{\varepsilon}{A} A = \varepsilon \end{aligned}$$

whenever  $n > N$ .

Now suppose  $(f_n)$  is a sequence of functions each *analytic* on some region  $D$ , and suppose the sequence converges uniformly on  $D$  to the function  $f$ . Then  $f$  is analytic. This result is in marked contrast to what happens with real functions—examples of uniformly convergent sequences of differentiable functions with a nondifferentiable limit abound in the real case. To see that this uniform limit is analytic, let  $z_0 \in D$ , and let  $S = \{z : |z - z_0| < r\} \subset D$ . Now consider any simple closed curve  $C \subset S$ . Each  $f_n$  is analytic, and so  $\int_C f_n(z) dz = 0$  for every  $n$ . From the uniform convergence of  $(f_n)$ , we know that  $\int_C f(z) dz$  is the limit of the sequence  $\left( \int_C f_n(z) dz \right)$ , and so  $\int_C f(z) dz = 0$ . Morera's theorem now tells us that  $f$  is analytic on  $S$ , and hence at  $z_0$ . Truly a miracle.

## Exercises

1. Prove that a sequence cannot have more than one limit. (We thus speak of *the* limit of a sequence.)
2. Give an example of a sequence that does not have a limit, or explain carefully why there is no such sequence.
3. Give an example of a bounded sequence that does not have a limit, or explain carefully why there is no such sequence.
4. Give a sequence  $(f_n)$  of functions continuous on a set  $D$  with a limit that is not continuous.
5. Give a sequence of real functions differentiable on an interval which converges uniformly to a nondifferentiable function.

**8.2 Series.** A series is simply a sequence  $(s_n)$  in which  $s_n = a_1 + a_2 + \dots + a_n$ . In other words, there is sequence  $(a_n)$  so that  $s_n = s_{n-1} + a_n$ . The  $s_n$  are usually called the **partial sums**. Recall from Mrs. Turner's class that if the series  $\left(\sum_{j=1}^n a_j\right)$  has a limit, then it must be true that  $\lim_{n \rightarrow \infty} (a_n) = 0$ .

Consider a series  $\left(\sum_{j=1}^n f_j(z)\right)$  of functions. Chances are this series will converge for some values of  $z$  and not converge for others. A useful result is the celebrated **Weierstrass M-test**: Suppose  $(M_j)$  is a sequence of real numbers such that  $M_j \geq 0$  for all  $j > J$ , where  $J$  is some number., and suppose also that the series  $\left(\sum_{j=1}^n M_j\right)$  converges. If for all  $z \in D$ , we have  $|f_j(z)| \leq M_j$  for all  $j > J$ , then the series  $\left(\sum_{j=1}^n f_j(z)\right)$  converges uniformly on  $D$ .

To prove this, begin by letting  $\varepsilon > 0$  and choosing  $N > J$  so that

$$\sum_{j=m}^n M_j < \varepsilon$$

for all  $n, m > N$ . (We can do this because of the famous Cauchy criterion.) Next, observe that

$$\left| \sum_{j=m}^n f_j(z) \right| \leq \sum_{j=m}^n |f_j(z)| \leq \sum_{j=m}^n M_j < \varepsilon.$$

This shows that  $\left( \sum_{j=1}^n f_j(z) \right)$  converges. To see the uniform convergence, observe that

$$\left| \sum_{j=m}^n f_j(z) \right| = \left| \sum_{j=0}^n f_j(z) - \sum_{j=0}^{m-1} f_j(z) \right| < \varepsilon$$

for all  $z \in D$  and  $n > m > N$ . Thus,

$$\lim_{n \rightarrow \infty} \left| \sum_{j=0}^n f_j(z) - \sum_{j=0}^{m-1} f_j(z) \right| = \left| \sum_{j=0}^{\infty} f_j(z) - \sum_{j=0}^{m-1} f_j(z) \right| \leq \varepsilon$$

for  $m > N$ . (The limit of a series  $\left( \sum_{j=0}^n a_j \right)$  is almost always written as  $\sum_{j=0}^{\infty} a_j$ .)

### Exercises

6. Find the set  $D$  of all  $z$  for which the sequence  $\left( \frac{z^n}{z^n - 3^n} \right)$  has a limit. Find the limit.

7. Prove that the series  $\left( \sum_{j=1}^n a_j \right)$  converges if and only if both the series  $\left( \sum_{j=1}^n \operatorname{Re} a_j \right)$  and  $\left( \sum_{j=1}^n \operatorname{Im} a_j \right)$  converge.

8. Explain how you know that the series  $\left( \sum_{j=1}^n \left( \frac{1}{z} \right)^j \right)$  converges uniformly on the set  $|z| \geq 5$ .

**8.3 Power series.** We are particularly interested in series of functions in which the partial sums are polynomials of increasing degree:

$$s_n(z) = c_0 + c_1(z - z_0) + c_2(z - z_0)^2 + \dots + c_n(z - z_0)^n.$$

(We start with  $n = 0$  for esthetic reasons.) These are the so-called **power series**. Thus, a power series is a series of functions of the form  $\left(\sum_{j=0}^n c_j(z - z_0)^j\right)$ .

Let's look first at a very special power series, the so-called **Geometric series**:

$$\left(\sum_{j=0}^n z^j\right).$$

Here

$$s_n = 1 + z + z^2 + \dots + z^n, \text{ and}$$

$$zs_n = z + z^2 + z^3 + \dots + z^{n+1}.$$

Subtracting the second of these from the first gives us

$$(1 - z)s_n = 1 - z^{n+1}.$$

If  $z = 1$ , then we can't go any further with this, but I hope it's clear that the series does not have a limit in case  $z = 1$ . Suppose now  $z \neq 1$ . Then we have

$$s_n = \frac{1}{1 - z} - \frac{z^{n+1}}{1 - z}.$$

Now if  $|z| < 1$ , it should be clear that  $\lim(z^{n+1}) = 0$ , and so

$$\lim\left(\sum_{j=0}^n z^j\right) = \lim s_n = \frac{1}{1 - z}.$$

Or,

$$\sum_{j=0}^{\infty} z^j = \frac{1}{1 - z}, \text{ for } |z| < 1.$$

There is a bit more to the story. First, note that if  $|z| > 1$ , then the Geometric series does not have a limit (why?). Next, note that if  $|z| \leq \rho < 1$ , then the Geometric series converges



uniformly to  $\frac{1}{1-z}$ . To see this, note that

$$\left( \sum_{j=0}^n \rho^j \right)$$

has a limit and appeal to the Weierstrass M-test.

Clearly a power series will have a limit for some values of  $z$  and perhaps not for others. First, note that any power series has a limit when  $z = z_0$ . Let's see what else we can say.

Consider a power series  $\left( \sum_{j=0}^n c_j (z - z_0)^j \right)$ . Let

$$\lambda = \limsup \left( \sqrt[j]{|c_j|} \right).$$

(Recall from 6<sup>th</sup> grade that  $\limsup(a_k) = \lim(\sup\{a_k : k \geq n\})$ .) Now let  $R = \frac{1}{\lambda}$ . (We shall say  $R = 0$  if  $\lambda = \infty$ , and  $R = \infty$  if  $\lambda = 0$ .) We are going to show that the series converges uniformly for all  $|z - z_0| \leq \rho < R$  and diverges for all  $|z - z_0| > R$ .

First, let's show the series does not converge for  $|z - z_0| > R$ . To begin, let  $k$  be so that

$$\frac{1}{|z - z_0|} < k < \frac{1}{R} = \lambda.$$

There are an infinite number of  $c_j$  for which  $\sqrt[j]{|c_j|} > k$ , otherwise  $\limsup \left( \sqrt[j]{|c_j|} \right) \leq k$ . For each of these  $c_j$  we have

$$|c_j (z - z_0)^j| = \left( \sqrt[j]{|c_j|} |z - z_0| \right)^j > (k|z - z_0|)^j > 1.$$

It is thus not possible for  $\lim_{n \rightarrow \infty} |c_n (z - z_0)^n| = 0$ , and so the series does not converge.

Next, we show that the series *does* converge uniformly for  $|z - z_0| \leq \rho < R$ . Let  $k$  be so that

$$\lambda = \frac{1}{R} < k < \frac{1}{\rho}.$$

Now, for  $j$  large enough, we have  $\sqrt[j]{|c_j|} < k$ . Thus for  $|z - z_0| \leq \rho$ , we have

$$|c_j(z - z_0)^j| = \left(\sqrt[j]{|c_j|} |z - z_0|\right)^j < (k|z - z_0|)^j < (k\rho)^j.$$

The geometric series  $\left(\sum_{j=0}^n (k\rho)^j\right)$  converges because  $k\rho < 1$  and the uniform convergence of  $\left(\sum_{j=0}^n c_j(z - z_0)^j\right)$  follows from the M-test.

### Example

Consider the series  $\left(\sum_{j=0}^n \frac{1}{j!} z^j\right)$ . Let's compute  $R = 1/\limsup\left(\sqrt[j]{|c_j|}\right) = \limsup(\sqrt[j]{j!})$ . Let  $K$  be any positive integer and choose an integer  $m$  large enough to insure that  $2^m > \frac{K^{2K}}{(2K)!}$ . Now consider  $\frac{n!}{K^n}$ , where  $n = 2K + m$ :

$$\begin{aligned} \frac{n!}{K^n} &= \frac{(2K + m)!}{K^{2K+m}} = \frac{(2K + m)(2K + m - 1)\dots(2K + 1)(2K)!}{K^m K^{2K}} \\ &> 2^m \frac{(2K)!}{K^{2K}} > 1 \end{aligned}$$

Thus  $\sqrt[n]{n!} > K$ . Reflect on what we have just shown: given any number  $K$ , there is a number  $n$  such that  $\sqrt[n]{n!}$  is bigger than it. In other words,  $R = \limsup(\sqrt[j]{j!}) = \infty$ , and so the series  $\left(\sum_{j=0}^n \frac{1}{j!} z^j\right)$  converges for all  $z$ .

Let's summarize what we have. For any power series  $\left(\sum_{j=0}^n c_j(z - z_0)^j\right)$ , there is a number  $R = \frac{1}{\limsup(\sqrt[j]{|c_j|})}$  such that the series converges uniformly for  $|z - z_0| \leq \rho < R$  and does not converge for  $|z - z_0| > R$ . (Note that we may have  $R = 0$  or  $R = \infty$ .) The number  $R$  is called the **radius of convergence** of the series, and the set  $|z - z_0| = R$  is called the **circle of convergence**. Observe also that the limit of a power series is a function analytic inside the circle of convergence (why?).

### Exercises

9. Suppose the sequence of real numbers  $(\alpha_j)$  has a limit. Prove that

$$\limsup(\alpha_j) = \lim(\alpha_j).$$

For each of the following, find the set  $D$  of points at which the series converges:

10.  $\left( \sum_{j=0}^n j! z^j \right).$

11.  $\left( \sum_{j=0}^n j z^j \right).$

12.  $\left( \sum_{j=0}^n \frac{j^2}{3^j} z^j \right).$

13.  $\left( \sum_{j=0}^n \frac{(-1)^j}{2^{2j}(j!)^2} z^{2j} \right)$

**8.4 Integration of power series.** Inside the circle of convergence, the limit

$$S(z) = \sum_{j=0}^{\infty} c_j (z - z_0)^j$$

is an analytic function. We shall show that this series may be integrated "term-by-term"—that is, the integral of the limit is the limit of the integrals. Specifically, if  $C$  is any contour inside the circle of convergence, and the function  $g$  is continuous on  $C$ , then

$$\int_C g(z) S(z) dz = \sum_{j=0}^{\infty} c_j \int_C g(z) (z - z_0)^j dz.$$

Let's see why this. First, let  $\varepsilon > 0$ . Let  $M$  be the maximum of  $|g(z)|$  on  $C$  and let  $L$  be the length of  $C$ . Then there is an integer  $N$  so that

$$\left| \sum_{j=n}^{\infty} c_j (z - z_0)^j \right| < \frac{\varepsilon}{ML}$$

for all  $n > N$ . Thus,

$$\left| \int_C \left( g(z) \sum_{j=n}^{\infty} c_j (z - z_0)^j \right) dz \right| < ML \frac{\varepsilon}{ML} = \varepsilon,$$

Hence,

$$\left| \int_C g(z) S(z) dz - \sum_{j=0}^{n-1} c_j \int_C g(z) (z - z_0)^j dz \right| = \left| \int_C \left( g(z) \sum_{j=n}^{\infty} c_j (z - z_0)^j \right) dz \right| < \varepsilon,$$

and we have shown what we promised.

**8.5 Differentiation of power series.** Again, let

$$S(z) = \sum_{j=0}^{\infty} c_j (z - z_0)^j.$$

Now we are ready to show that inside the circle of convergence,

$$S'(z) = \sum_{j=1}^{\infty} j c_j (z - z_0)^{j-1}.$$

Let  $z$  be a point inside the circle of convergence and let  $C$  be a positive oriented circle centered at  $z$  and inside the circle of convergence. Define

$$g(s) = \frac{1}{2\pi i (s - z)^2},$$

and apply the result of the previous section to conclude that

$$\int_C g(s)S(s)ds = \sum_{j=0}^{\infty} c_j \int_C g(s)(s - z_0)^j ds, \text{ or}$$

$$\frac{1}{2\pi i} \int_C \frac{S(s)}{(s - z)^2} ds = \sum_{j=0}^{\infty} c_j \int_C \frac{(s - z_0)^j}{(s - z)^2} ds. \text{ Thus}$$

$$S'(z) = \sum_{j=0}^{\infty} j c_j (z - z_0)^{j-1},$$

as promised!

### Exercises

14. Find the limit of

$$\left( \sum_{j=0}^n (j + 1)z^j \right).$$

For what values of  $z$  does the series converge?

15. Find the limit of

$$\left( \sum_{j=1}^n \frac{z^j}{j} \right).$$

For what values of  $z$  does the series converge?

16. Find a power series  $\left( \sum_{j=0}^n c_j (z - 1)^j \right)$  such that

$$\frac{1}{z} = \sum_{j=0}^{\infty} c_j (z - 1)^j, \text{ for } |z - 1| < 1.$$

17. Find a power series  $\left( \sum_{j=0}^n c_j (z - 1)^j \right)$  such that

$$\text{Log } z = \sum_{j=0}^{\infty} c_j (z-1)^j, \text{ for } |z-1| < 1.$$

## Chapter Nine

# Taylor and Laurent Series

**9.1. Taylor series.** Suppose  $f$  is analytic on the open disk  $|z - z_0| < r$ . Let  $z$  be any point in this disk and choose  $C$  to be the positively oriented circle of radius  $\rho$ , where  $|z - z_0| < \rho < r$ . Then for  $s \in C$  we have

$$\frac{1}{s-z} = \frac{1}{(s-z_0) - (z-z_0)} = \frac{1}{s-z_0} \left[ \frac{1}{1 - \frac{z-z_0}{s-z_0}} \right] = \sum_{j=0}^{\infty} \frac{(z-z_0)^j}{(s-z_0)^{j+1}}$$

since  $|\frac{z-z_0}{s-z_0}| < 1$ . The convergence is uniform, so we may integrate

$$\int_C \frac{f(s)}{s-z} ds = \sum_{j=0}^{\infty} \left( \int_C \frac{f(s)}{(s-z_0)^{j+1}} ds \right) (z-z_0)^j, \text{ or}$$
$$f(z) = \frac{1}{2\pi i} \int_C \frac{f(s)}{s-z} ds = \sum_{j=0}^{\infty} \left( \frac{1}{2\pi i} \int_C \frac{f(s)}{(s-z_0)^{j+1}} ds \right) (z-z_0)^j.$$

We have thus produced a power series having the given analytic function as a limit:

$$f(z) = \sum_{j=0}^{\infty} c_j (z-z_0)^j, \quad |z-z_0| < r,$$

where

$$c_j = \frac{1}{2\pi i} \int_C \frac{f(s)}{(s-z_0)^{j+1}} ds.$$

This is the celebrated **Taylor Series** for  $f$  at  $z = z_0$ .

We know we may differentiate the series to get

$$f'(z) = \sum_{j=1}^{\infty} j c_j (z-z_0)^{j-1}$$

and this one converges uniformly where the series for  $f$  does. We can thus differentiate again and again to obtain

$$f^{(n)}(z) = \sum_{j=n}^{\infty} j(j-1)(j-2)\dots(j-n+1)c_j(z-z_0)^{j-n}.$$

Hence,

$$\begin{aligned} f^{(n)}(z_0) &= n!c_n, \text{ or} \\ c_n &= \frac{f^{(n)}(z_0)}{n!}. \end{aligned}$$

But we also know that

$$c_n = \frac{1}{2\pi i} \int_C \frac{f(s)}{(s-z_0)^{n+1}} ds.$$

This gives us

$$f^{(n)}(z_0) = \frac{n!}{2\pi i} \int_C \frac{f(s)}{(s-z_0)^{n+1}} ds, \text{ for } n = 0, 1, 2, \dots$$

This is the famous **Generalized Cauchy Integral Formula**. Recall that we previously derived this formula for  $n = 0$  and 1.

What does all this tell us about the radius of convergence of a power series? Suppose we have

$$f(z) = \sum_{j=0}^{\infty} c_j(z-z_0)^j,$$

and the radius of convergence is  $R$ . Then we know, of course, that the limit function  $f$  is analytic for  $|z-z_0| < R$ . We showed that if  $f$  is analytic in  $|z-z_0| < r$ , then the series converges for  $|z-z_0| < r$ . Thus  $r \leq R$ , and so  $f$  cannot be analytic at any point  $z$  for which  $|z-z_0| > R$ . In other words, the circle of convergence is the largest circle centered at  $z_0$  inside of which the limit  $f$  is analytic.



### Example

Let  $f(z) = \exp(z) = e^z$ . Then  $f(0) = f'(0) = \dots = f^{(n)}(0) = \dots = 1$ , and the Taylor series for  $f$  at  $z_0 = 0$  is

$$e^z = \sum_{j=0}^{\infty} \frac{1}{j!} z^j$$

and this is valid for all values of  $z$  since  $f$  is entire. (We also showed earlier that this particular series has an infinite radius of convergence.)

### Exercises

1. Show that for all  $z$ ,

$$e^z = e \sum_{j=0}^{\infty} \frac{1}{j!} (z-1)^j.$$

2. What is the radius of convergence of the Taylor series  $\left( \sum_{j=0}^n c_j z^j \right)$  for  $\tanh z$ ?

3. Show that

$$\frac{1}{1-z} = \sum_{j=0}^{\infty} \frac{(z-i)^j}{(1-i)^{j+1}}$$

for  $|z-i| < \sqrt{2}$ .

4. If  $f(z) = \frac{1}{1-z}$ , what is  $f^{(10)}(i)$ ?

5. Suppose  $f$  is analytic at  $z = 0$  and  $f(0) = f'(0) = f''(0) = 0$ . Prove there is a function  $g$  analytic at 0 such that  $f(z) = z^3 g(z)$  in a neighborhood of 0.

6. Find the Taylor series for  $f(z) = \sin z$  at  $z_0 = 0$ .

7. Show that the function  $f$  defined by

$$f(z) = \begin{cases} \frac{\sin z}{z} & \text{for } z \neq 0 \\ 1 & \text{for } z = 0 \end{cases}$$

is analytic at  $z = 0$ , and find  $f'(0)$ .

**9.2. Laurent series.** Suppose  $f$  is analytic in the region  $R_1 < |z - z_0| < R_2$ , and let  $C$  be a positively oriented simple closed curve around  $z_0$  in this region. (Note: we include the possibilities that  $R_1$  can be 0, and  $R_2 = \infty$ .) We shall show that for  $z \notin C$  in this region

$$f(z) = \sum_{j=0}^{\infty} a_j(z - z_0)^j + \sum_{j=1}^{\infty} \frac{b_j}{(z - z_0)^j},$$

where

$$a_j = \frac{1}{2\pi i} \int_C \frac{f(s)}{(s - z_0)^{j+1}} ds, \text{ for } j = 0, 1, 2, \dots$$

and

$$b_j = \frac{1}{2\pi i} \int_C \frac{f(s)}{(s - z_0)^{-j+1}} ds, \text{ for } j = 1, 2, \dots$$

The sum of the limits of these two series is frequently written

$$f(z) = \sum_{j=-\infty}^{\infty} c_j(z - z_0)^j,$$

where

$$c_j = \frac{1}{2\pi i} \int_C \frac{f(s)}{(s - z_0)^{j+1}} ds, j = 0, \pm 1, \pm 2, \dots$$

This recipe for  $f(z)$  is called a **Laurent series**, although it is important to keep in mind that it is really two series.

Okay, now let's derive the above formula. First, let  $r_1$  and  $r_2$  be so that  $R_1 < r_1 \leq |z - z_0| \leq r_2 < R_2$  and so that the point  $z$  and the curve  $C$  are included in the region  $r_1 \leq |z - z_0| \leq r_2$ . Also, let  $\Gamma$  be a circle centered at  $z$  and such that  $\Gamma$  is included in this region.

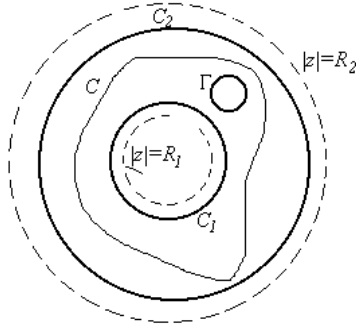

Then  $\frac{f(s)}{s-z}$  is an analytic function (of  $s$ ) on the region bounded by  $C_1, C_2$ , and  $\Gamma$ , where  $C_1$  is the circle  $|z| = r_1$  and  $C_2$  is the circle  $|z| = r_2$ . Thus,

$$\int_{C_2} \frac{f(s)}{s-z} ds = \int_{C_1} \frac{f(s)}{s-z} ds + \int_{\Gamma} \frac{f(s)}{s-z} ds.$$

(All three circles are positively oriented, of course.) But  $\int_{\Gamma} \frac{f(s)}{s-z} ds = 2\pi if(z)$ , and so we have

$$2\pi if(z) = \int_{C_2} \frac{f(s)}{s-z} ds - \int_{C_1} \frac{f(s)}{s-z} ds.$$

Look at the first of the two integrals on the right-hand side of this equation. For  $s \in C_2$ , we have  $|z - z_0| < |s - z_0|$ , and so

$$\begin{aligned} \frac{1}{s-z} &= \frac{1}{(s-z_0) - (z-z_0)} \\ &= \frac{1}{s-z_0} \left[ \frac{1}{1 - \left(\frac{z-z_0}{s-z_0}\right)} \right] \\ &= \frac{1}{s-z_0} \sum_{j=0}^{\infty} \left(\frac{z-z_0}{s-z_0}\right)^j \\ &= \sum_{j=0}^{\infty} \frac{1}{(s-z_0)^{j+1}} (z-z_0)^j. \end{aligned}$$

Hence,

$$\begin{aligned} \int_{C_2} \frac{f(s)}{s-z} ds &= \sum_{j=0}^{\infty} \left( \int_{C_2} \frac{f(s)}{(s-z_0)^{j+1}} ds \right) (z-z_0)^j \\ &= \sum_{j=0}^{\infty} \left( \int_C \frac{f(s)}{(s-z_0)^{j+1}} ds \right) (z-z_0)^j \end{aligned}$$

For the second of these two integrals, note that for  $s \in C_1$  we have  $|s-z_0| < |z-z_0|$ , and so

$$\begin{aligned} \frac{1}{s-z} &= \frac{-1}{(z-z_0) - (s-z_0)} = \frac{-1}{z-z_0} \left[ \frac{1}{1 - \left(\frac{s-z_0}{z-z_0}\right)} \right] \\ &= \frac{-1}{z-z_0} \sum_{j=0}^{\infty} \left(\frac{s-z_0}{z-z_0}\right)^j = - \sum_{j=0}^{\infty} (s-z_0)^j \frac{1}{(z-z_0)^{j+1}} \\ &= - \sum_{j=1}^{\infty} (s-z_0)^{j-1} \frac{1}{(z-z_0)^j} = - \sum_{j=1}^{\infty} \left( \frac{1}{(s-z_0)^{-j+1}} \right) \frac{1}{(z-z_0)^j} \end{aligned}$$

As before,

$$\begin{aligned} \int_{C_1} \frac{f(s)}{s-z} ds &= - \sum_{j=1}^{\infty} \left( \int_{C_2} \frac{f(s)}{(s-z_0)^{-j+1}} ds \right) \frac{1}{(z-z_0)^j} \\ &= - \sum_{j=1}^{\infty} \left( \int_C \frac{f(s)}{(s-z_0)^{-j+1}} ds \right) \frac{1}{(z-z_0)^j} \end{aligned}$$

Putting this altogether, we have the Laurent series:

$$\begin{aligned} f(z) &= \frac{1}{2\pi i} \int_{C_2} \frac{f(s)}{s-z} ds - \frac{1}{2\pi i} \int_{C_1} \frac{f(s)}{s-z} ds \\ &= \sum_{j=0}^{\infty} \left( \frac{1}{2\pi i} \int_C \frac{f(s)}{(s-z_0)^{j+1}} ds \right) (z-z_0)^j + \sum_{j=1}^{\infty} \left( \frac{1}{2\pi i} \int_C \frac{f(s)}{(s-z_0)^{-j+1}} ds \right) \frac{1}{(z-z_0)^j}. \end{aligned}$$

**Example**

Let  $f$  be defined by

$$f(z) = \frac{1}{z(z-1)}.$$

First, observe that  $f$  is analytic in the region  $0 < |z| < 1$ . Let's find the Laurent series for  $f$  valid in this region. First,

$$f(z) = \frac{1}{z(z-1)} = -\frac{1}{z} + \frac{1}{z-1}.$$

From our vast knowledge of the Geometric series, we have

$$f(z) = -\frac{1}{z} - \sum_{j=0}^{\infty} z^j.$$

Now let's find another Laurent series for  $f$ , the one valid for the region  $1 < |z| < \infty$ . First,

$$\frac{1}{z-1} = \frac{1}{z} \left[ \frac{1}{1 - \frac{1}{z}} \right].$$

Now since  $|\frac{1}{z}| < 1$ , we have

$$\frac{1}{z-1} = \frac{1}{z} \left[ \frac{1}{1 - \frac{1}{z}} \right] = \frac{1}{z} \sum_{j=0}^{\infty} z^{-j} = \sum_{j=1}^{\infty} z^{-j},$$

and so

$$f(z) = -\frac{1}{z} + \frac{1}{z-1} = -\frac{1}{z} + \sum_{j=1}^{\infty} z^{-j}$$
$$f(z) = \sum_{j=2}^{\infty} z^{-j}.$$

## Exercises

8. Find two Laurent series in powers of  $z$  for the function  $f$  defined by

$$f(z) = \frac{1}{z^2(1-z)}$$

and specify the regions in which the series converge to  $f(z)$ .

**9.** Find two Laurent series in powers of  $z$  for the function  $f$  defined by

$$f(z) = \frac{1}{z(1+z^2)}$$

and specify the regions in which the series converge to  $f(z)$ .

**10.** Find the Laurent series in powers of  $z - 1$  for  $f(z) = \frac{1}{z}$  in the region  $1 < |z - 1| < \infty$ .

## Chapter Ten

# Poles, Residues, and All That

**10.1. Residues.** A point  $z_0$  is a **singular point** of a function  $f$  if  $f$  is not analytic at  $z_0$ , but is analytic at some point of each neighborhood of  $z_0$ . A singular point  $z_0$  of  $f$  is said to be *isolated* if there is a neighborhood of  $z_0$  which contains no singular points of  $f$  save  $z_0$ . In other words,  $f$  is analytic on some region  $0 < |z - z_0| < \varepsilon$ .

### Examples

The function  $f$  given by

$$f(z) = \frac{1}{z(z^2 + 4)}$$

has isolated singular points at  $z = 0$ ,  $z = 2i$ , and  $z = -2i$ .

Every point on the negative real axis and the origin is a singular point of  $\text{Log } z$ , but there are *no* isolated singular points.

Suppose now that  $z_0$  is an isolated singular point of  $f$ . Then there is a Laurent series

$$f(z) = \sum_{j=-\infty}^{\infty} c_j (z - z_0)^j$$

valid for  $0 < |z - z_0| < R$ , for some positive  $R$ . The coefficient  $c_{-1}$  of  $(z - z_0)^{-1}$  is called the **residue** of  $f$  at  $z_0$ , and is frequently written

$$\text{Res}_{z=z_0} f.$$

Now, why do we care enough about  $c_{-1}$  to give it a special name? Well, observe that if  $C$  is any positively oriented simple closed curve in  $0 < |z - z_0| < R$  and which contains  $z_0$  inside, then

$$c_{-1} = \frac{1}{2\pi i} \int_C f(z) dz.$$

This provides the key to evaluating many complex integrals.

### Example

We shall evaluate the integral

$$\int_C e^{1/z} dz$$

where  $C$  is the circle  $|z| = 1$  with the usual positive orientation. Observe that the integrand has an isolated singularity at  $z = 0$ . We know then that the value of the integral is simply  $2\pi i$  times the residue of  $e^{1/z}$  at 0. Let's find the Laurent series about 0. We already know that

$$e^z = \sum_{j=0}^{\infty} \frac{1}{j!} z^j$$

for all  $z$ . Thus,

$$e^{1/z} = \sum_{j=0}^{\infty} \frac{1}{j!} z^{-j} = 1 + \frac{1}{z} + \frac{1}{2!} \frac{1}{z^2} + \dots$$

The residue  $c_{-1} = 1$ , and so the value of the integral is simply  $2\pi i$ .

Now suppose we have a function  $f$  which is analytic everywhere except for isolated singularities, and let  $C$  be a simple closed curve (positively oriented) on which  $f$  is analytic. Then there will be only a finite number of singularities of  $f$  inside  $C$  (why?). Call them  $z_1, z_2, \dots, z_n$ . For each  $k = 1, 2, \dots, n$ , let  $C_k$  be a positively oriented circle centered at  $z_k$  and with radius small enough to insure that it is inside  $C$  and has no other singular points inside it.



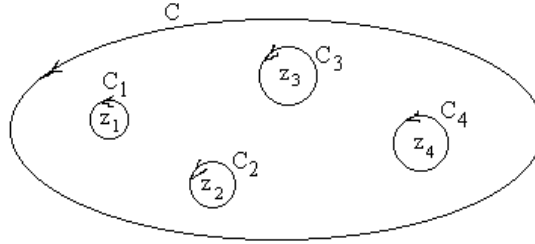

Then,

$$\begin{aligned}
 \int_C f(z) dz &= \int_{C_1} f(z) dz + \int_{C_2} f(z) dz + \dots + \int_{C_n} f(z) dz \\
 &= 2\pi i \operatorname{Res}_{z=z_1} f + 2\pi i \operatorname{Res}_{z=z_2} f + \dots + 2\pi i \operatorname{Res}_{z=z_n} f \\
 &= 2\pi i \sum_{k=1}^n \operatorname{Res}_{z=z_k} f.
 \end{aligned}$$

This is the celebrated **Residue Theorem**. It says that the integral of  $f$  is simply  $2\pi i$  times the sum of the residues at the singular points enclosed by the contour  $C$ .

### Exercises

Evaluate the integrals. In each case,  $C$  is the positively oriented circle  $|z| = 2$ .

1.  $\int_C e^{1/z^2} dz.$

2.  $\int_C \sin\left(\frac{1}{z}\right) dz.$

3.  $\int_C \cos\left(\frac{1}{z}\right) dz.$

4.  $\int_C \frac{1}{z} \sin\left(\frac{1}{z}\right) dz.$

5.  $\int_C \frac{1}{z} \cos\left(\frac{1}{z}\right) dz.$

**10.2. Poles and other singularities.** In order for the Residue Theorem to be of much help in evaluating integrals, there needs to be some better way of computing the residue—finding the Laurent expansion about each isolated singular point is a chore. We shall now see that in the case of a special but commonly occurring type of singularity the residue is easy to find. Suppose  $z_0$  is an isolated singularity of  $f$  and suppose that the Laurent series of  $f$  at  $z_0$  contains only a finite number of terms involving negative powers of  $z - z_0$ . Thus,

$$f(z) = \frac{c_{-n}}{(z - z_0)^n} + \frac{c_{-n+1}}{(z - z_0)^{n-1}} + \dots + \frac{c_{-1}}{(z - z_0)} + c_0 + c_1(z - z_0) + \dots$$

Multiply this expression by  $(z - z_0)^n$  :

$$\phi(z) = (z - z_0)^n f(z) = c_{-n} + c_{-n+1}(z - z_0) + \dots + c_{-1}(z - z_0)^{n-1} + \dots$$

What we see is the Taylor series at  $z_0$  for the function  $\phi(z) = (z - z_0)^n f(z)$ . The coefficient of  $(z - z_0)^{n-1}$  is what we seek, and we know that this is

$$\frac{\phi^{(n-1)}(z_0)}{(n-1)!}$$

The sought after residue  $c_{-1}$  is thus

$$c_{-1} = \operatorname{Res}_{z=z_0} f = \frac{\phi^{(n-1)}(z_0)}{(n-1)!},$$

where  $\phi(z) = (z - z_0)^n f(z)$ .

### Example

We shall find all the residues of the function

$$f(z) = \frac{e^z}{z^2(z^2 + 1)}.$$

First, observe that  $f$  has isolated singularities at 0, and  $\pm i$ . Let's see about the residue at 0. Here we have

$$\phi(z) = z^2 f(z) = \frac{e^z}{(z^2 + 1)}.$$

The residue is simply  $\phi'(0)$  :

$$\phi'(z) = \frac{(z^2 + 1)e^z - 2ze^z}{(z^2 + 1)^2}.$$

Hence,

$$\operatorname{Res}_{z=0} f = \phi'(0) = 1.$$

Next, let's see what we have at  $z = i$ :

$$\phi(z) = (z - i)f(z) = \frac{e^z}{z^2(z + i)},$$

and so

$$\operatorname{Res}_{z=i} f(z) = \phi(i) = -\frac{e^i}{2i}.$$

In the same way, we see that

$$\operatorname{Res}_{z=-i} f = \frac{e^{-i}}{2i}.$$

Let's find the integral  $\int_C \frac{e^z}{z^2(z^2+1)} dz$ , where  $C$  is the contour pictured:

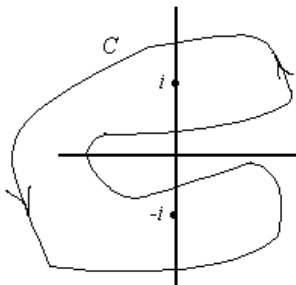

This is now easy. The contour is positive oriented and encloses two singularities of  $f$ ; viz,  $i$  and  $-i$ . Hence,

$$\begin{aligned} \int_C \frac{e^z}{z^2(z^2+1)} dz &= 2\pi i \left[ \operatorname{Res}_{z=i} f + \operatorname{Res}_{z=-i} f \right] \\ &= 2\pi i \left[ -\frac{e^i}{2i} + \frac{e^{-i}}{2i} \right] \\ &= -2\pi i \sin 1. \end{aligned}$$

Miraculously easy!

There is some jargon that goes with all this. An isolated singular point  $z_0$  of  $f$  such that the Laurent series at  $z_0$  includes only a finite number of terms involving negative powers of  $z - z_0$  is called a **pole**. Thus, if  $z_0$  is a pole, there is an integer  $n$  so that  $\phi(z) = (z - z_0)^n f(z)$  is analytic at  $z_0$ , and  $\phi(z_0) \neq 0$ . The number  $n$  is called the **order** of the pole. Thus, in the preceding example,  $0$  is a pole of order 2, while  $i$  and  $-i$  are poles of order 1. (A pole of order 1 is frequently called a **simple pole**.) We must hedge just a bit here. If  $z_0$  is an isolated singularity of  $f$  and there are *no* Laurent series terms involving negative powers of  $z - z_0$ , then we say  $z_0$  is a **removable** singularity.

### Example

Let

$$f(z) = \frac{\sin z}{z};$$

then the singularity  $z = 0$  is a removable singularity:

$$\begin{aligned} f(z) &= \frac{1}{z} \sin z = \frac{1}{z} \left( z - \frac{z^3}{3!} + \frac{z^5}{5!} - \dots \right) \\ &= 1 - \frac{z^2}{3!} + \frac{z^4}{5!} - \dots \end{aligned}$$

and we see that in some sense  $f$  is "really" analytic at  $z = 0$  if we would just define it to be the right thing there.

A singularity that is neither a pole or removable is called an **essential** singularity.

Let's look at one more labor-saving trick—or technique, if you prefer. Suppose  $f$  is a function:

$$f(z) = \frac{p(z)}{q(z)},$$

where  $p$  and  $q$  are analytic at  $z_0$ , and we have  $q(z_0) = 0$ , while  $q'(z_0) \neq 0$ , and  $p(z_0) \neq 0$ . Then

$$f(z) = \frac{p(z)}{q(z)} = \frac{p(z_0) + p'(z_0)(z - z_0) + \dots}{q'(z_0)(z - z_0) + \frac{q''(z_0)}{2}(z - z_0)^2 + \dots},$$

and so

$$\phi(z) = (z - z_0)f(z) = \frac{p(z_0) + p'(z_0)(z - z_0) + \dots}{q'(z_0) + \frac{q''(z_0)}{2}(z - z_0) + \dots}.$$

Thus  $z_0$  is a simple pole and

$$\operatorname{Res}_{z=z_0} f = \phi(z_0) = \frac{p(z_0)}{q'(z_0)}.$$

### Example

Find the integral

$$\int_C \frac{\cos z}{e^z - 1} dz,$$

where  $C$  is the rectangle with sides  $x = \pm 1$ ,  $y = -\pi$ , and  $y = 3\pi$ .

The singularities of the integrand are all the places at which  $e^z = 1$ , or in other words, the points  $z = 0, \pm 2\pi i, \pm 4\pi i, \dots$ . The singularities enclosed by  $C$  are 0 and  $2\pi i$ . Thus,

$$\int_C \frac{\cos z}{e^z - 1} dz = 2\pi i \left[ \operatorname{Res}_{z=0} f + \operatorname{Res}_{z=2\pi i} f \right],$$

where

$$f(z) = \frac{\cos z}{e^z - 1}.$$

Observe this is precisely the situation just discussed:  $f(z) = \frac{p(z)}{q(z)}$ , where  $p$  and  $q$  are analytic, *etc., etc.* Now,

$$\frac{p(z)}{q'(z)} = \frac{\cos z}{e^z}.$$

Thus,

$$\begin{aligned} \operatorname{Res}_{z=0} f &= \frac{\cos 0}{1} = 1, \text{ and} \\ \operatorname{Res}_{z=2\pi i} f &= \frac{\cos 2\pi i}{e^{2\pi i}} = \frac{e^{-2\pi} + e^{2\pi}}{2} = \cosh 2\pi. \end{aligned}$$

Finally,

$$\begin{aligned} \int_C \frac{\cos z}{e^z - 1} dz &= 2\pi i \left[ \operatorname{Res}_{z=0} f + \operatorname{Res}_{z=2\pi i} f \right] \\ &= 2\pi i(1 + \cosh 2\pi) \end{aligned}$$

### Exercises

6. Suppose  $f$  has an isolated singularity at  $z_0$ . Then, of course, the derivative  $f'$  also has an isolated singularity at  $z_0$ . Find the residue  $\operatorname{Res}_{z=z_0} f'$ .
7. Given an example of a function  $f$  with a simple pole at  $z_0$  such that  $\operatorname{Res}_{z=z_0} f = 0$ , or explain carefully why there is no such function.
8. Given an example of a function  $f$  with a pole of order 2 at  $z_0$  such that  $\operatorname{Res}_{z=z_0} f = 0$ , or explain carefully why there is no such function.
9. Suppose  $g$  is analytic and has a zero of order  $n$  at  $z_0$  (That is,  $g(z) = (z - z_0)^n h(z)$ , where  $h(z_0) \neq 0$ ). Show that the function  $f$  given by

$$f(z) = \frac{1}{g(z)}$$

has a pole of order  $n$  at  $z_0$ . What is  $\operatorname{Res}_{z=z_0} f$ ?

**10.** Suppose  $g$  is analytic and has a zero of order  $n$  at  $z_0$ . Show that the function  $f$  given by

$$f(z) = \frac{g'(z)}{g(z)}$$

has a simple pole at  $z_0$ , and  $\operatorname{Res}_{z=z_0} f = n$ .

**11.** Find

$$\int_C \frac{\cos z}{z^2 - 4} dz,$$

where  $C$  is the positively oriented circle  $|z| = 6$ .

**12.** Find

$$\int_C \tan z dz,$$

where  $C$  is the positively oriented circle  $|z| = 2\pi$ .

**13.** Find

$$\int_C \frac{1}{z^2 + z + 1} dz,$$

where  $C$  is the positively oriented circle  $|z| = 10$ .

## Chapter Eleven

### Argument Principle

**11.1. Argument principle.** Let  $C$  be a simple closed curve, and suppose  $f$  is analytic on  $C$ . Suppose moreover that the only singularities of  $f$  inside  $C$  are poles. If  $f(z) \neq 0$  for all  $z \in C$ , then  $\Gamma = f(C)$  is a closed curve which does not pass through the origin. If

$$\gamma(t), \alpha \leq t \leq \beta$$

is a complex description of  $C$ , then

$$\zeta(t) = f(\gamma(t)), \alpha \leq t \leq \beta$$

is a complex description of  $\Gamma$ . Now, let's compute

$$\int_C \frac{f'(z)}{f(z)} dz = \int_{\alpha}^{\beta} \frac{f'(\gamma(t))}{f(\gamma(t))} \gamma'(t) dt.$$

But notice that  $\zeta'(t) = f'(\gamma(t))\gamma'(t)$ . Hence,

$$\begin{aligned} \int_C \frac{f'(z)}{f(z)} dz &= \int_{\alpha}^{\beta} \frac{f'(\gamma(t))}{f(\gamma(t))} \gamma'(t) dt = \int_{\alpha}^{\beta} \frac{\zeta'(t)}{\zeta(t)} dt \\ &= \int_{\Gamma} \frac{1}{z} dz = n2\pi i, \end{aligned}$$

where  $|n|$  is the number of times  $\Gamma$  "winds around" the origin. The integer  $n$  is positive in case  $\Gamma$  is traversed in the positive direction, and negative in case the traversal is in the negative direction.

Next, we shall use the Residue Theorem to evaluate the integral  $\int_C \frac{f'(z)}{f(z)} dz$ . The singularities of the integrand  $\frac{f'(z)}{f(z)}$  are the poles of  $f$  together with the zeros of  $f$ . Let's find the residues at these points. First, let  $Z = \{z_1, z_2, \dots, z_K\}$  be set of all zeros of  $f$ . Suppose the order of the zero  $z_j$  is  $n_j$ . Then  $f(z) = (z - z_j)^{n_j} h(z)$  and  $h(z_j) \neq 0$ . Thus,



$$\begin{aligned}\frac{f'(z)}{f(z)} &= \frac{(z-z_j)^{n_j}h'(z) + n_j(z-z_j)^{n_j-1}h(z)}{(z-z_j)^{n_j}h(z)} \\ &= \frac{h'(z)}{h(z)} + \frac{n_j}{(z-z_j)}.\end{aligned}$$

Then

$$\phi(z) = (z-z_j)\frac{f'(z)}{f(z)} = (z-z_j)\frac{h'(z)}{h(z)} + n_j,$$

and

$$\operatorname{Res}_{z=z_j} \frac{f'}{f} = n_j.$$

The sum of all these residues is thus

$$N = n_1 + n_2 + \dots + n_K.$$

Next, we go after the residues at the poles of  $f$ . Let the set of poles of  $f$  be  $P = \{p_1, p_2, \dots, p_J\}$ . Suppose  $p_j$  is a pole of order  $m_j$ . Then

$$h(z) = (z-p_j)^{m_j}f(z)$$

is analytic at  $p_j$ . In other words,

$$f(z) = \frac{h(z)}{(z-p_j)^{m_j}}.$$

Hence,

$$\begin{aligned}\frac{f'(z)}{f(z)} &= \frac{(z-p_j)^{m_j}h'(z) - m_j(z-p_j)^{m_j-1}h(z)}{(z-p_j)^{2m_j}} \cdot \frac{(z-p_j)^{m_j}}{h(z)} \\ &= \frac{h'(z)}{h(z)} - \frac{m_j}{(z-p_j)^{m_j}}.\end{aligned}$$

Now then,

$$\phi(z) = (z - p_j)^{m_j} \frac{f'(z)}{f(z)} = (z - p_j)^{m_j} \frac{h'(z)}{h(z)} - m_j,$$

and so

$$\operatorname{Res}_{z=p_j} \frac{f'}{f} = \phi(p_j) = -m_j.$$

The sum of all these residues is

$$-P = -m_1 - m_2 - \dots - m_J$$

Then,

$$\int_C \frac{f'(z)}{f(z)} dz = 2\pi i(N - P);$$

and we already found that

$$\int_C \frac{f'(z)}{f(z)} dz = n2\pi i,$$

where  $n$  is the "winding number", or the number of times  $\Gamma$  winds around the origin— $n > 0$  means  $\Gamma$  winds in the positive sense, and  $n$  negative means it winds in the negative sense. Finally, we have

$$n = N - P,$$

where  $N = n_1 + n_2 + \dots + n_K$  is the number of zeros inside  $C$ , counting multiplicity, or the order of the zeros, and  $P = m_1 + m_2 + \dots + m_J$  is the number of poles, counting the order. This result is the celebrated **argument principle**.

### Exercises

1. Let  $C$  be the unit circle  $|z| = 1$  positively oriented, and let  $f$  be given by

$$f(z) = z^3.$$

How many times does the curve  $f(C)$  wind around the origin? Explain.

2. Let  $C$  be the unit circle  $|z| = 1$  positively oriented, and let  $f$  be given by

$$f(z) = \frac{z^2 + 2}{z^3}.$$

How many times does the curve  $f(C)$  wind around the origin? Explain.

3. Let  $p(z) = a_n z^n + a_{n-1} z^{n-1} + \dots + a_1 z + a_0$ , with  $a_n \neq 0$ . Prove there is an  $R > 0$  so that if  $C$  is the circle  $|z| = R$  positively oriented, then

$$\int_C \frac{p'(z)}{p(z)} dz = 2n\pi i.$$

4. How many solutions of  $3e^z - z = 0$  are in the disk  $|z| \leq 1$ ? Explain.

5. Suppose  $f$  is entire and  $f(z)$  is real if and only if  $z$  is real. Explain how you know that  $f$  has at most one zero.

**11.2 Rouché's Theorem.** Suppose  $f$  and  $g$  are analytic on and inside a simple closed contour  $C$ . Suppose moreover that  $|f(z)| > |g(z)|$  for all  $z \in C$ . Then we shall see that  $f$  and  $f + g$  have the same number of zeros inside  $C$ . This result is **Rouché's Theorem**. To see why it is so, start by defining the function  $\Psi(t)$  on the interval  $0 \leq t \leq 1$ :

$$\Psi(t) = \frac{1}{2\pi i} \int_C \frac{f'(z) + tg'(t)}{f(z) + tg(z)} dz.$$

Observe that this is okay—that is, the denominator of the integrand is never zero:

$$|f(z) + tg(z)| \geq \|f(t)\| - t\|g(t)\| \geq \|f(t)\| - \|g(t)\| > 0.$$

Observe that  $\Psi$  is continuous on the interval  $[0, 1]$  and is integer-valued— $\Psi(t)$  is the

number of zeros of  $f + tg$  inside  $C$ . Being continuous and integer-valued on the connected set  $[0, 1]$ , it must be constant. In particular,  $\Psi(0) = \Psi(1)$ . This does the job!

$$\Psi(0) = \frac{1}{2\pi i} \int_C \frac{f'(z)}{f(z)} dz$$

is the number of zeros of  $f$  inside  $C$ , and

$$\Psi(1) = \frac{1}{2\pi i} \int_C \frac{f'(z) + g'(z)}{f(z) + g(z)} dz$$

is the number of zeros of  $f + g$  inside  $C$ .

### Example

How many solutions of the equation  $z^6 - 5z^5 + z^3 - 2 = 0$  are inside the circle  $|z| = 1$ ? Rouché's Theorem makes it quite easy to answer this. Simply let  $f(z) = -5z^5$  and let  $g(z) = z^6 + z^3 - 2$ . Then  $|f(z)| = 5$  and  $|g(z)| \leq |z|^6 + |z|^3 + 2 = 4$  for all  $|z| = 1$ . Hence  $|f(z)| > |g(z)|$  on the unit circle. From Rouché's Theorem we know then that  $f$  and  $f + g$  have the same number of zeros inside  $|z| = 1$ . Thus, there are 5 such solutions.

The following nice result follows easily from Rouché's Theorem. Suppose  $U$  is an open set (*i.e.*, every point of  $U$  is an interior point) and suppose that a sequence  $(f_n)$  of functions analytic on  $U$  converges uniformly to the function  $f$ . Suppose further that  $f$  is not zero on the circle  $C = \{z : |z - z_0| = R\} \subset U$ . Then there is an integer  $N$  so that for all  $n \geq N$ , the functions  $f_n$  and  $f$  have the same number of zeros inside  $C$ .

This result, called **Hurwitz's Theorem**, is an easy consequence of Rouché's Theorem. Simply observe that for  $z \in C$ , we have  $|f(z)| > \varepsilon > 0$  for some  $\varepsilon$ . Now let  $N$  be large enough to insure that  $|f_n(z) - f(z)| < \varepsilon$  on  $C$ . It follows from Rouché's Theorem that  $f$  and  $f + (f_n - f) = f_n$  have the same number of zeros inside  $C$ .

### Example

On any bounded set, the sequence  $(f_n)$ , where  $f_n(z) = 1 + z + \frac{z^2}{2} + \dots + \frac{z^n}{n!}$ , converges uniformly to  $f(z) = e^z$ , and  $f(z) \neq 0$  for all  $z$ . Thus for any  $R$ , there is an  $N$  so that for  $n > N$ , every zero of  $1 + z + \frac{z^2}{2} + \dots + \frac{z^n}{n!}$  has modulus  $> R$ . Or to put it another way, given an  $R$  there is an  $N$  so that for  $n > N$  no polynomial  $1 + z + \frac{z^2}{2} + \dots + \frac{z^n}{n!}$  has a zero inside the

circle of radius  $R$ .

### Exercises

6. Show that the polynomial  $z^6 + 4z^2 - 1$  has exactly two zeros inside the circle  $|z| = 1$ .

7. How many solutions of  $2z^4 - 2z^3 + 2z^2 - 2z + 9 = 0$  lie inside the circle  $|z| = 1$ ?

8. Use Rouché's Theorem to prove that every polynomial of degree  $n$  has exactly  $n$  zeros (counting multiplicity, of course).

9. Let  $C$  be the closed unit disk  $|z| \leq 1$ . Suppose the function  $f$  analytic on  $C$  maps  $C$  into the open unit disk  $|z| < 1$ —that is,  $|f(z)| < 1$  for all  $z \in C$ . Prove there is exactly one  $w \in C$  such that  $f(w) = w$ . (The point  $w$  is called a **fixed point** of  $f$ .)